

TIP PROJECT: U-6053

CONTRACT: DM00238

STATE	STATE PROJECT REFERENCE NO.	SHEET NO.	TOTAL SHEETS
N.C.	U-6053	1	
STATE PROJ. NO.	F.A. PROJ. NO.	DESCRIPTION	
46961.1.1	APD - 0040 (056)	P.E.	
46.961.3.1	APD - 0040 (056)	CONST.	

**STATE OF NORTH CAROLINA  
DIVISION OF HIGHWAYS**

**BUNCOMBE COUNTY**

**LOCATION: ACCESS ROAD SR 2870 IN  
BLACK MOUNTAIN, NC**

**TYPE OF WORK: GRADING, PAVING, DRAINAGE,  
AND PAVEMENT MARKINGS**

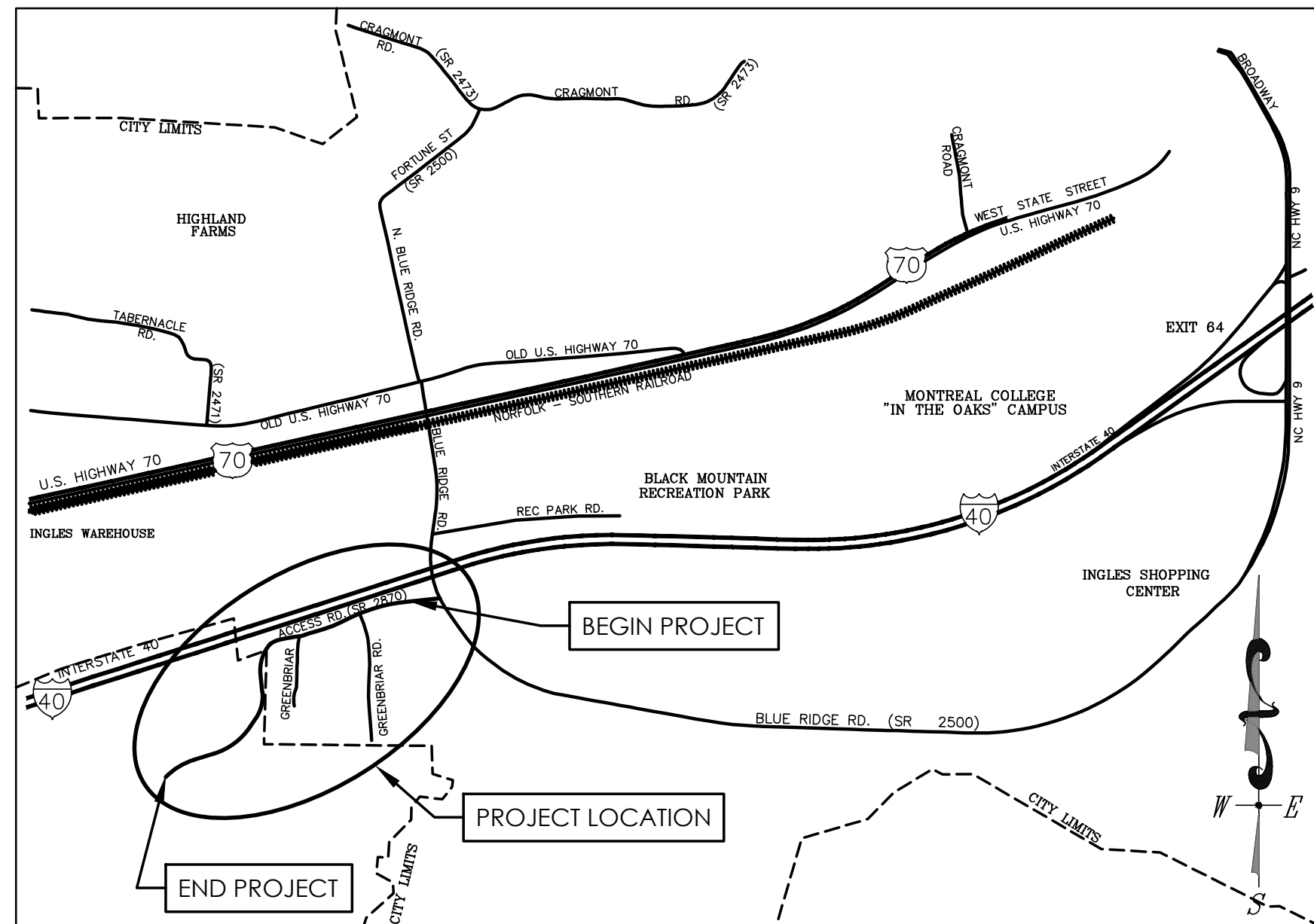

**VICINITY MAP**

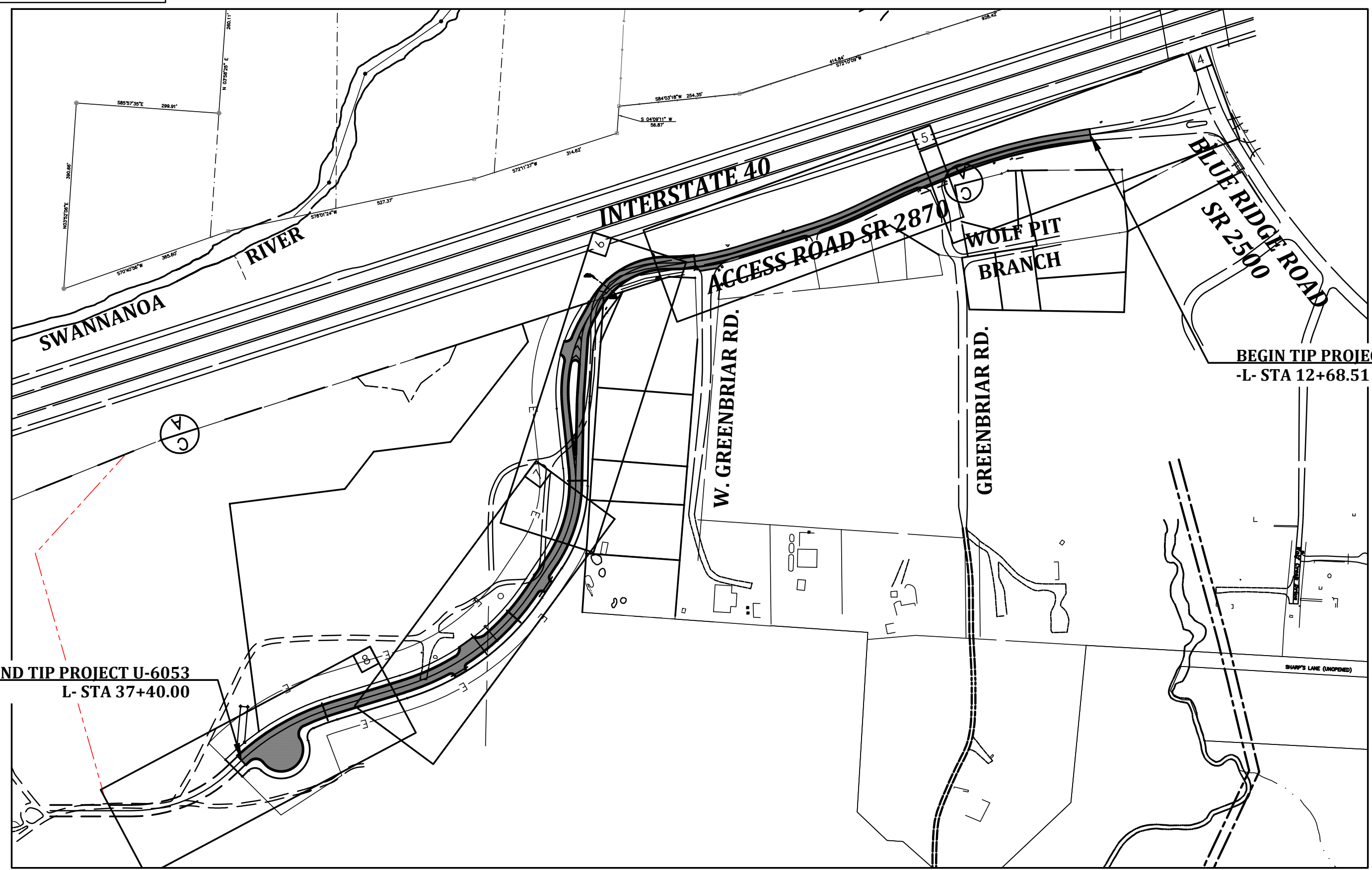

NAD 83/2011

**GRAPHIC SCALES**

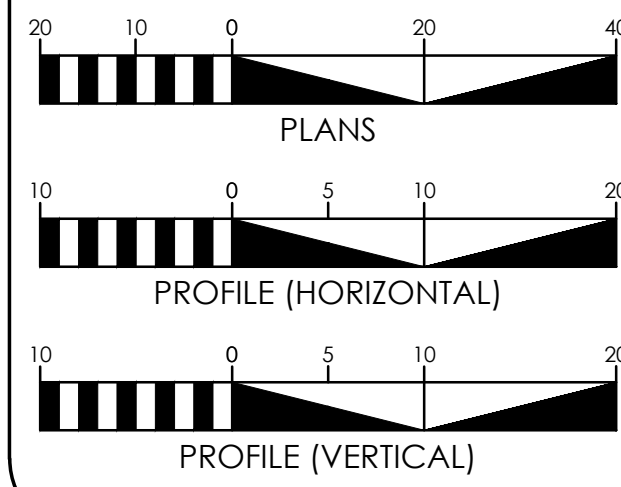

**DESIGN DATA**

ADT 2018 = 113  
 ADT 2038 = 412  
 K = \_\_\_  
 D = \_\_\_  
 T = \_\_\_  
 V = 30 MPH  
 FUNC CLASS =  
 RURAL LOCAL

**PROJECT LENGTH**

LENGTH OF ROADWAY PROJECT U-6053 = 0.468 MILE  
 LENGTH OF STRUCTURE PROJECT U-6053 = 0.000 MILE  
 TOTAL LENGTH OF PROJECT U-6053 = 0.468 MILE

**PLANS PREPARED BY:**



2018 STANDARD SPECIFICATIONS	BRIAN R. NEWMAN, PE PROJECT ENGINEER
RIGHT OF WAY DATE: -	MATTHEW D. OETTING, PE PROJECT DESIGN ENGINEER
LETTING DATE: MAY 02, 2018	

NCDOT CONTACT: TROY S. WILSON, PLS DIV 13 DISTRICT ENGINEER

**HYDRAULICS ENGINEER**

**ROADWAY DESIGN ENGINEER**

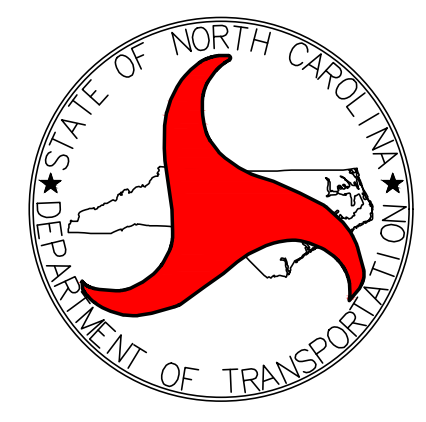
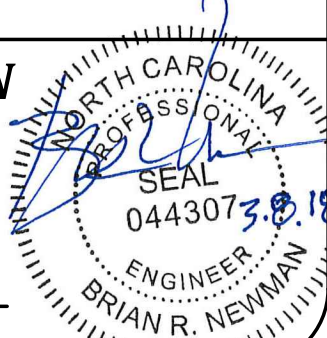
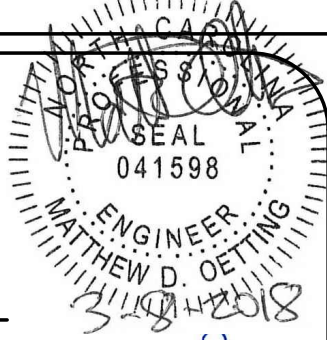

PROJECT REFERENCE NO. <b>U-6053</b>	SHEET NO. <b>1-A</b>
 <b>McGill</b> ASSOCIATES ENGINEERING · PLANNING · FINANCE <small>10010 STREET LINE AV. · RALEIGH, NC 27601 · PH: (919) 215-2000 · FAX: (919) 215-4000</small>	
	

**STATE OF NORTH CAROLINA  
DIVISION OF HIGHWAYS**

# INDEX OF SHEETS, GENERAL NOTES, LIST OF STANDARD DRAWINGS

## STANDARD DRAWINGS

2018 ROADWAY ENGLISH STANDARD DRAWINGS

The following Roadway Standards appear in "Roadway Standard Drawings" Highway Design Branch - N.C. Department of Transportation - Raleigh, N.C., Dated January, 2018 are applicable to this project and by reference hereby are considered a part of these plans:

STD. NO.	TITLE
<u>DIVISION 2 - EARTHWORK</u>	
200.02	METHOD OF CLEARING - METHOD II
225.02	GUIDE FOR GRADING SUBGRADE - SECONDARY AND LOCAL
225.04	METHOD OF OBTAINING SUPERELEVATION - TWO LANE PAVEMENT
240.01	GUIDE FOR BERM DITCH CONSTRUCTION
<u>DIVISION 3 - PIPE CULVERTS</u>	
300.01	METHOD OF PIPE INSTALLATION
310.03	CROSS PIPE END SECTION
<u>DIVISION 6 - ASPHALT BASES AND PAVEMENTS</u>	
654.01	PAVEMENT REPAIRS
<u>DIVISION 8 - INCIDENTALS</u>	
806.01	CONCRETE RIGHT-OF-WAY MARKER
806.02	GRANITE RIGHT-OF-WAY MARKER
838.80	PRECAST CONCRETE ENDWALL
840.00	CONCRETE BASE PAD FOR DRAINAGE STRUCTURES
840.02	CONCRETE CATCH BASIN - 12" THRU 54" PIPE
840.03	FRAME, GRATES AND HOOD - FOR USE ON STANDARD CATCH BASIN
840.14	CONCRETE DROP INLET - 12" THRU 30" PIPE
840.16	DROP INLET FRAME AND GRATE
840.24	FRAME AND NARROW SLOT SAG GRATES
840.45	PRECAST DRAINAGE STRUCTURES
840.66	DRAINAGE STRUCTURE STEPS
840.72	PIPE COLLAR
846.01	CONCRETE CURB, GUTTER AND CURB AND GUTTER
848.04	STREET TURN OUT
852.01	CONCRETE ISLANDS
862.01	GUARDRAIL PLACEMENT
862.02	GUARDRAIL INSTALLATION
862.03	STRUCTURE ANCHOR UNITS
852.02	CONCRETE MOUNTABLE MEDIAN
876.02	GUIDE FOR RIP RAP AT PIPE OUTLETS
<u>DIVISION 11 - WORK ZONE TRAFFIC CONTROL</u>	
1101.02	TEMPORARY LANE CLOSURES - 2-LANE, 2-WAY ROADWAY - 1 LANE CLOSED
1145.01	BARRICADES - TYPE III
<u>DIVISION 12 - PAVEMENT MARKINGS, MARKERS AND DELINEATION</u>	
1205.01	PAVEMENT MARKINGS
1205.04	PAVEMENT MARKINGS - INTERSECTIONS SHEET 2 OF 2
1205.09	PAVEMENT MARKINGS - PAINTED ISLANDS
<u>DIVISION 16 - EROSION CONTROL AND ROADSIDE DEVELOPMENT</u>	
1605.01	TEMPORARY SILT FENCE
1607.01	GENERAL CONSTRUCTION ENTRANCE
1630.02	TEMPORARY SILT BASIN, TYPE B
1630.05	TEMPORARY DIVERSION
1631.01	MATTING INSTALLATION
1632.03	ROCK INLET SEDIMENT TRAP TYPE C
1633.01	TEMPORARY ROCK SILT CHECK TYPE A
1633.02	TEMPORARY ROCK SILT CHECK TYPE B
1645.01	CLEAN WATER DITCH (USE TEMP. STREAM CROSSING)

## INDEX OF SHEETS

<u>SHEET NUMBER:</u>	<u>SHEET TITLE</u>
1	TITLE SHEET
1A	INDEX OF SHEETS, GENERAL NOTES, AND STANDARD DRAWINGS
1B	CONVENTIONAL SYMBOLS
1C	SURVEY CONTROL SHEET
2 THRU 2A	TYPICAL SECTIONS
3A	DRAINAGE SUMMARY
3B	SUMMARY OF EARTHWORK SUMMARY OF EXISTING ASPHALT PAVEMENT REMOVAL GUARDRAIL SUMMARY
4 THRU 8	PLAN-PROFILE SHEETS
TMP-1	TRAFFIC CONTROL GENERAL NOTES AND PHASING NOTES
PMP-1 THRU PMP-4	PAVEMENT MARKING PLANS
EC-1 THRU EC-1C	EROSION CONTROL PLANS
X-1 THRU X-12	CROSS-SECTIONS

## GENERAL NOTES

GRADING AND SURFACING OR RESURFACING AND WIDENING:

THE GRADE LINES SHOWN DENOTE THE FINISHED ELEVATION OF THE PROPOSED SURFACING AT GRADE POINTS SHOWN ON THE TYPICAL SECTIONS. WHERE NO GRADE LINES ARE SHOWN, THE PROFILES SHOWN DENOTE THE TOP ELEVATION OF THE EXISTING PAVEMENT ALONG THE CENTER LINE OF SURVEY ON WHICH THE PROPOSED RESURFACING WILL BE PLACED. GRADE LINES MAY BE ADJUSTED BY THE ENGINEER IN ORDER TO SECURE A PROPER TIE-IN.

SUPERELEVATION:

ALL CURVES ON THIS PROJECT SHALL BE SUPERELEVATED IN ACCORDANCE WITH STD. NO. 225.04 USING THE RATE OF SUPERELEVATION AND RUNOFF SHOWN ON THE PLANS. SUPERELEVATION IS TO BE REVOLVED ABOUT THE GRADE POINTS SHOWN ON THE TYPICAL SECTIONS.

SHOULDER CONSTRUCTION:

ASPHALT, EARTH, AND CONCRETE SHOULDER CONSTRUCTION ON THE HIGH SIDE OF SUPERELEVATED CURVES SHALL BE IN ACCORDANCE WITH STD. NO. 560.01.

SIDE ROADS:

THE CONTRACTOR WILL BE REQUIRED TO DO ALL NECESSARY WORK TO PROVIDE SUITABLE CONNECTIONS WITH ALL ROADS, STREETS, AND DRIVES ENTERING THIS PROJECT. THIS WORK WILL BE PAID AT THE CONTRACT UNIT PRICE FOR THE PARTICULAR ITEMS INVOLVED.

BERM DITCHES:

BERM DITCHES SHALL BE CONSTRUCTED IN ACCORDANCE WITH STD. NO. 240.01 AT LOCATIONS SHOWN ON THE PLANS OR AS DIRECTED BY THE ENGINEER.

DRIVEWAYS:

DRIVEWAYS SHALL BE CONSTRUCTED IN ACCORDANCE WITH STD. 848.02 USING 3 FOOT RADII (NOT ACCEPTABLE FOR INDUSTRIAL TRAFFIC) OR RADII AS SHOWN ON THE PLANS. LOCATIONS OF DRIVES WILL BE AS SHOWN ON THE PLANS OR AS DIRECTED BY THE ENGINEER.

STREET TURNOUT:

STREET RETURNS SHALL BE CONSTRUCTED IN ACCORDANCE WITH STA. NO. 848.04 USING THE RADII NOTED ON THE PLANS.

GUARDRAIL:

THE GUARDRAIL LOCATIONS SHOWN ON THE PLANS MAY BE ADJUSTED DURING CONSTRUCTION AS DIRECTED BY THE ENGINEERS. THE CONTRACTOR SHOULD CONSULT WITH THE ENGINEER PRIOR TO ORDERING GUARDRAIL MATERIAL.

SUBSURFACE PLANS:

NO SUBSURFACE PLANS ARE AVAILABLE ON THIS PROJECT. THE CONTRACTOR SHOULD MAKE HIS OWN INVESTIGATION AS TO THE SUBSURFACE CONDITIONS.

UTILITIES:

UTILITY OWNERS AND CONTACTS ON THIS PROJECT ARE:

WATER:	TOWN OF BLACK MOUNTAIN	Jamey Matthews	828.664.5052
SEWER:	METROPOLITAN SEWERAGE DISTRICT (MSD)	Ed Bradford, PE	828.225.8261
ELECTRIC:	DUKE ENERGY CAROLINAS	Bill Roberts	828.234.1870
NAT GAS:	PSNC ENERGY	Lee McElrath, CEM	828.670.3525

ANY RELOCATION OF EXISTING UTILITIES WILL BE ACCOMPLISHED BY OTHERS, EXCEPT AS SHOWN ON THE PLANS HEREIN. SEE CIVIL DESIGN CONCEPTS CONSTRUCTION PLANS FOR MSD SANITARY SEWER AND TOWN WATERLINE EXTENSION INSTALLATION INFORMATION.

RIGHT-OF-WAY MARKERS:

ALL RIGHT-OF-WAY MARKERS ON THIS PROJECT SHALL BE PLACED BY CONTRACT.

CONDUITS:

ALL STEEL CASING AND PVC CONDUITS SHALL HAVE X,Y, AND Z COORDINATES AT ENDS AND RECORDED ON AS-BUILTS.

STATE OF NORTH CAROLINA  
DIVISION OF HIGHWAYS

# CONVENTIONAL PLAN SHEET SYMBOLS

**BOUNDARIES AND PROPERTY:**

State Line \_\_\_\_\_

County Line \_\_\_\_\_

Township Line \_\_\_\_\_

City Line \_\_\_\_\_

Reservation Line \_\_\_\_\_

Property Line \_\_\_\_\_

Existing Iron Pin \_\_\_\_\_ 

Property Corner \_\_\_\_\_ 

Property Monument \_\_\_\_\_ 

Parcel/Sequence Number \_\_\_\_\_ 

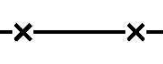
Existing Fence Line \_\_\_\_\_ 

Proposed Woven Wire Fence \_\_\_\_\_ 

Proposed Chain Link Fence \_\_\_\_\_ 

Proposed Barbed Wire Fence \_\_\_\_\_ 

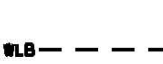
Existing Wetland Boundary \_\_\_\_\_ 

Proposed Wetland Boundary \_\_\_\_\_ 

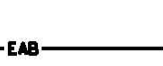
Existing Endangered Animal Boundary \_\_\_\_\_ 

Existing Endangered Plant Boundary \_\_\_\_\_ 

Known Soil Contamination: Area or Site \_\_\_\_\_ 

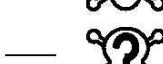
Potential Soil Contamination: Area or Site \_\_\_\_\_ 

**BUILDINGS AND OTHER CULTURE:**

Gas Pump Vent or U/G Tank Cap \_\_\_\_\_ 

Sign \_\_\_\_\_ 

Well \_\_\_\_\_ 

Small Mine \_\_\_\_\_ 

Foundation \_\_\_\_\_ 

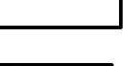
Area Outline \_\_\_\_\_ 

Cemetery \_\_\_\_\_ 

Building \_\_\_\_\_ 

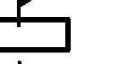
School \_\_\_\_\_ 

Church \_\_\_\_\_ 

Dam \_\_\_\_\_ 

**HYDROLOGY:**

Stream or Body of Water \_\_\_\_\_ 

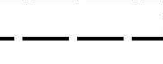
Hydro, Pool or Reservoir \_\_\_\_\_ 

Jurisdictional Stream \_\_\_\_\_ 

Buffer Zone 1 \_\_\_\_\_ 

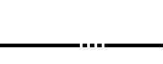
Buffer Zone 2 \_\_\_\_\_ 

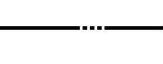
Flow Arrow \_\_\_\_\_ 

Disappearing Stream \_\_\_\_\_ 

Spring \_\_\_\_\_ 

Wetland \_\_\_\_\_ 

Proposed Lateral, Tail, Head Ditch \_\_\_\_\_ 

False Sump \_\_\_\_\_ 

**RAILROADS:**

Standard Gauge \_\_\_\_\_ 

RR Signal Milepost \_\_\_\_\_ 

Switch \_\_\_\_\_ 

RR Abandoned \_\_\_\_\_ 

RR Dismantled \_\_\_\_\_ 

**RIGHT OF WAY:**

Baseline Control Point \_\_\_\_\_ 

Existing Right of Way Marker \_\_\_\_\_ 

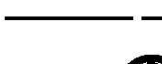
Existing Right of Way Line \_\_\_\_\_ 

Proposed Right of Way Line \_\_\_\_\_ 

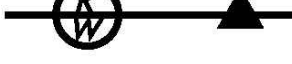
Proposed Right of Way Line with Iron Pin and Cap Marker \_\_\_\_\_ 

Proposed Right of Way Line with Concrete or Granite Marker \_\_\_\_\_ 

Existing Control of Access \_\_\_\_\_ 

Proposed Control of Access \_\_\_\_\_ 

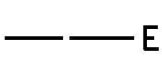
Existing Easement Line \_\_\_\_\_ 

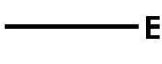
Proposed Temporary Construction Easement \_\_\_\_\_ 

Proposed Temporary Drainage Easement \_\_\_\_\_ 

Proposed Permanent Drainage Easement \_\_\_\_\_ 

Proposed Permanent Drainage / Utility Easement \_\_\_\_\_ 

Proposed Permanent Utility Easement \_\_\_\_\_ 

Proposed Temporary Utility Easement \_\_\_\_\_ 

Proposed Aerial Utility Easement \_\_\_\_\_ 

Proposed Permanent Easement with Iron Pin and Cap Marker \_\_\_\_\_ 

**ROADS AND RELATED FEATURES:**

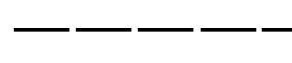
Existing Edge of Pavement \_\_\_\_\_ 

Existing Curb \_\_\_\_\_ 

Proposed Slope Stakes Cut \_\_\_\_\_ 

Proposed Slope Stakes Fill \_\_\_\_\_ 

Proposed Curb Ramp \_\_\_\_\_ 

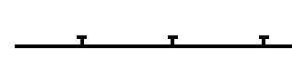
Curb Cut Future Ramp \_\_\_\_\_ 

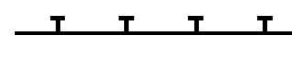
Existing Metal Guardrail \_\_\_\_\_ 

Proposed Guardrail \_\_\_\_\_ 

Existing Cable Guiderail \_\_\_\_\_ 

Proposed Cable Guiderail \_\_\_\_\_ 

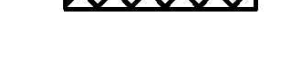
Equality Symbol \_\_\_\_\_ 

Pavement Removal \_\_\_\_\_ 

**VEGETATION:**

Single Tree \_\_\_\_\_ 

Single Shrub \_\_\_\_\_ 

Hedge \_\_\_\_\_ 

Woods Line \_\_\_\_\_ 

Orchard \_\_\_\_\_ 

Vineyard \_\_\_\_\_ 

**EXISTING STRUCTURES:**

MAJOR:

Bridge, Tunnel or Box Culvert \_\_\_\_\_ 

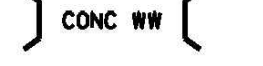
Bridge Wing Wall, Head Wall and End Wall \_\_\_\_\_ 

MINOR:

Head and End Wall \_\_\_\_\_ 

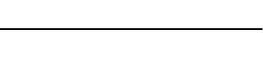
Pipe Culvert \_\_\_\_\_ 

Footbridge \_\_\_\_\_ 

Drainage Box: Catch Basin, DI or JB \_\_\_\_\_ 

Paved Ditch Gutter \_\_\_\_\_ 

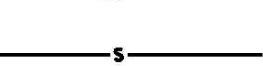
Storm Sewer Manhole \_\_\_\_\_ 

Storm Sewer \_\_\_\_\_ 

**UTILITIES:**

POWER:

Existing Power Pole \_\_\_\_\_ 

Proposed Power Pole \_\_\_\_\_ 

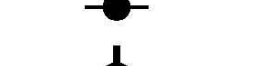
Existing Joint Use Pole \_\_\_\_\_ 

Proposed Joint Use Pole \_\_\_\_\_ 

Power Manhole \_\_\_\_\_ 

Power Line Tower \_\_\_\_\_ 

Power Transformer \_\_\_\_\_ 

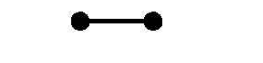
U/G Power Cable Hand Hole \_\_\_\_\_ 

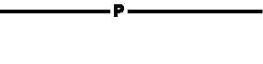
H-Frame Pole \_\_\_\_\_ 

Recorded U/G Power Line \_\_\_\_\_ 

Designated U/G Power Line (S.U.E.\*) \_\_\_\_\_ 

TELEPHONE:

Existing Telephone Pole \_\_\_\_\_ 

Proposed Telephone Pole \_\_\_\_\_ 

Telephone Manhole \_\_\_\_\_ 

Telephone Booth \_\_\_\_\_ 

Telephone Pedestal \_\_\_\_\_ 

Telephone Cell Tower \_\_\_\_\_ 

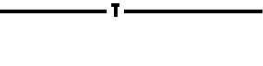
U/G Telephone Cable Hand Hole \_\_\_\_\_ 

Recorded U/G Telephone Cable \_\_\_\_\_ 

Designated U/G Telephone Cable (S.U.E.\*) \_\_\_\_\_ 

Recorded U/G Telephone Conduit \_\_\_\_\_ 

Designated U/G Telephone Conduit (S.U.E.\*) \_\_\_\_\_ 

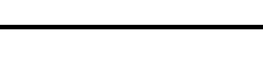
Recorded U/G Fiber Optics Cable \_\_\_\_\_ 

Designated U/G Fiber Optics Cable (S.U.E.\*) \_\_\_\_\_ 

**WATER:**

Water Manhole \_\_\_\_\_ 

Water Meter \_\_\_\_\_ 

Water Valve \_\_\_\_\_ 

Water Hydrant \_\_\_\_\_ 

Recorded U/G Water Line \_\_\_\_\_ 

Designated U/G Water Line (S.U.E.\*) \_\_\_\_\_ 

Above Ground Water Line \_\_\_\_\_ 

**TV:**

TV Satellite Dish \_\_\_\_\_ 

TV Pedestal \_\_\_\_\_ 

TV Tower \_\_\_\_\_ 

U/G TV Cable Hand Hole \_\_\_\_\_ 

Recorded U/G TV Cable \_\_\_\_\_ 

Designated U/G TV Cable (S.U.E.\*) \_\_\_\_\_ 

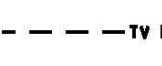
Recorded U/G Fiber Optic Cable \_\_\_\_\_ 

Designated U/G Fiber Optic Cable (S.U.E.\*) \_\_\_\_\_ 

**GAS:**

Gas Valve \_\_\_\_\_ 

Gas Meter \_\_\_\_\_ 

Recorded U/G Gas Line \_\_\_\_\_ 

Designated U/G Gas Line (S.U.E.\*) \_\_\_\_\_ 

Above Ground Gas Line \_\_\_\_\_ 

**SANITARY SEWER:**

Sanitary Sewer Manhole \_\_\_\_\_ 

Sanitary Sewer Cleanout \_\_\_\_\_ 

U/G Sanitary Sewer Line \_\_\_\_\_ 

Above Ground Sanitary Sewer \_\_\_\_\_ 

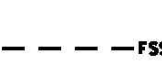
Recorded SS Forced Main Line \_\_\_\_\_ 

Designated SS Forced Main Line (S.U.E.\*) \_\_\_\_\_ 

**MISCELLANEOUS:**

Utility Pole \_\_\_\_\_ 

Utility Pole with Base \_\_\_\_\_ 

Utility Located Object \_\_\_\_\_ 

Utility Traffic Signal Box \_\_\_\_\_ 

Utility Unknown U/G Line \_\_\_\_\_ 

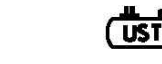
U/G Tank; Water, Gas, Oil \_\_\_\_\_ 

Underground Storage Tank, Approx. Loc. \_\_\_\_\_ 

A/G Tank; Water, Gas, Oil \_\_\_\_\_ 

Geoenvironmental Boring \_\_\_\_\_ 

U/G Test Hole (S.U.E.\*) \_\_\_\_\_ 

Abandoned According to Utility Records \_\_\_\_\_ 

End of Information \_\_\_\_\_ 

# STATE OF NORTH CAROLINA DIVISION OF HIGHWAYS

## SURVEY CONTROL SHEET

-L- ALIGNMENT COORDINATES			-L- ALIGNMENT COORDINATES		
STATION	NORTHING	EASTING	STATION	NORTHING	EASTING
10+00	692127.1148	1007268.9485	29+00	691212.5213	1005899.1624
11+00	692102.5983	1007172.0004	30+00	691128.5689	1005846.6254
12+00	692080.7468	1007074.4407	31+00	691049.2187	1005785.9935
13+00	692064.8223	1006975.7194	32+00	690983.2183	1005711.0892
14+00	692046.9597	1006877.3540	33+00	690933.4148	1005624.5657
15+00	692019.9965	1006781.0986	34+00	690900.4730	1005530.2403
16+00	691985.7413	1006687.1658	35+00	690871.2705	1005434.5992
17+00	691945.7003	1006595.5513	36+00	690835.4954	1005341.3733
18+00	691902.6451	1006505.2999	37+00	690782.1470	1005256.9893
19+00	691867.2999	1006411.8106	38+00	690715.6085	1005182.4267
20+00	691837.6587	1006316.3050	39+00	690667.5866	1005095.2393
21+00	691810.2625	1006220.1827			
22+00	691799.9393	1006120.8844			
23+00	691773.2206	1006026.0003			
24+00	691698.7351	1005961.1701			
25+00	691607.6586	1005920.7028			
26+00	691508.5750	1005911.2054			
27+00	691409.1260	1005921.6687			
28+00	691309.4524	1005925.7140			

### SURVEY CONTROL POINTS U-6053

BL POINT	DESCRIPT.	NORTHING	EASTING	ELEVATION	-L- STA.	-L- OFFSET
1535	BL-1	692048.168	1007269.799	2293.38	10+18.53	76.75 LT.
1502	BL-2	691755.339	1006234.291	2317.87	20+97.56	56.65 LT.
5900	BL-3	691717.103	1005955.057	2275.47	23+86.96	14.31 RT.

### DESIGN ALIGNMENTS

-L- ALIGNMENT			
TYPE	STATION	NORTHING	EASTING
PC	11+17.45	692098.2716	1007154.8910
PT	12+31.40	692075.4776	1007043.4878
PC	13+29.98	692060.1656	1006946.1026
PCC	14+87.12	692023.9857	1006793.3493
PT	16+92.76	691948.8341	1006602.0767
PC	17+56.84	691921.0924	1006544.3120
PT	19+15.59	691862.7438	1006396.9062
PC	20+50.93	694822.5231	1006267.6727
PRC	22+02.99	691799.9375	1006117.8949
PT	23+86.61	691713.0309	1005969.1796
PC	24+25.46	691676.5231	1005948.7254
PT	26+10.69	691497.9299	1005912.1544
PC	27+36.98	691372.3613	1005925.6077
PT	29+45.50	691173.9085	1005876.8738
PC	30+19.92	691112.0008	1005835.5720
PT	33+62.97	690911.2858	1005545.6531
PC	35+16.29	690866.5138	1005419.0208
PT	37+62.60	690740.6010	1005210.2237
PC	37+64.35	690739.3579	1005208.9895

-Y- ALIGNMENT			
TYPE	STATION	NORTHING	EASTING
PC	24+14.95	691685.6890	1005953.8608
PT	24+65.43	691637.6944	1005939.5776
PC	25+76.03	691527.3571	1005932.0769
PT	25+99.11	691504.2997	1005931.0371

### PERMANENT EASEMENTS

ROW MARKER PERMANENT EASEMENT - E					
LINE	STATION	OFFSET	NORTHING	EASTING	
-L-	36+66.06	80.09 RT.	690868.4165	1005239.4640	
-L-	36+75.93	89.67 RT.	690869.7206	1005224.5208	
-L-	37+10.99	24.36 RT.	690794.1300	1005232.9809	
-L-	37+31.37	24.37 RT.	690780.2722	1005216.7145	

### TEMPORARY EASEMENTS

LINE	STATION	OFFSET	NORTHING	EASTING
-L-	24+45.06	74.55 RT.	691691.2311	1005872.4344
-L-	28+88.71	50.00 LT.	691204.2401	1005950.2275
-L-	35+50.00	50.00 LT.	690808.2146	1005405.1708
-L-	36+52.45	74.34 RT.	690872.2426	1005255.7281
-L-	35+50.00	140.00 LT.	690724.7481	1005436.9381
-L-	37+62.92	140.00 LT.	690641.7281	1005309.3414
-L-	37+62.92	74.40 RT.	690792.7893	1005157.2007

### ROW MARKERS

ALIGN.	STATION	OFFSET	NORTHING	EASTING
PC	10+18.53	76.75 LT.	692048.168	1007269.799

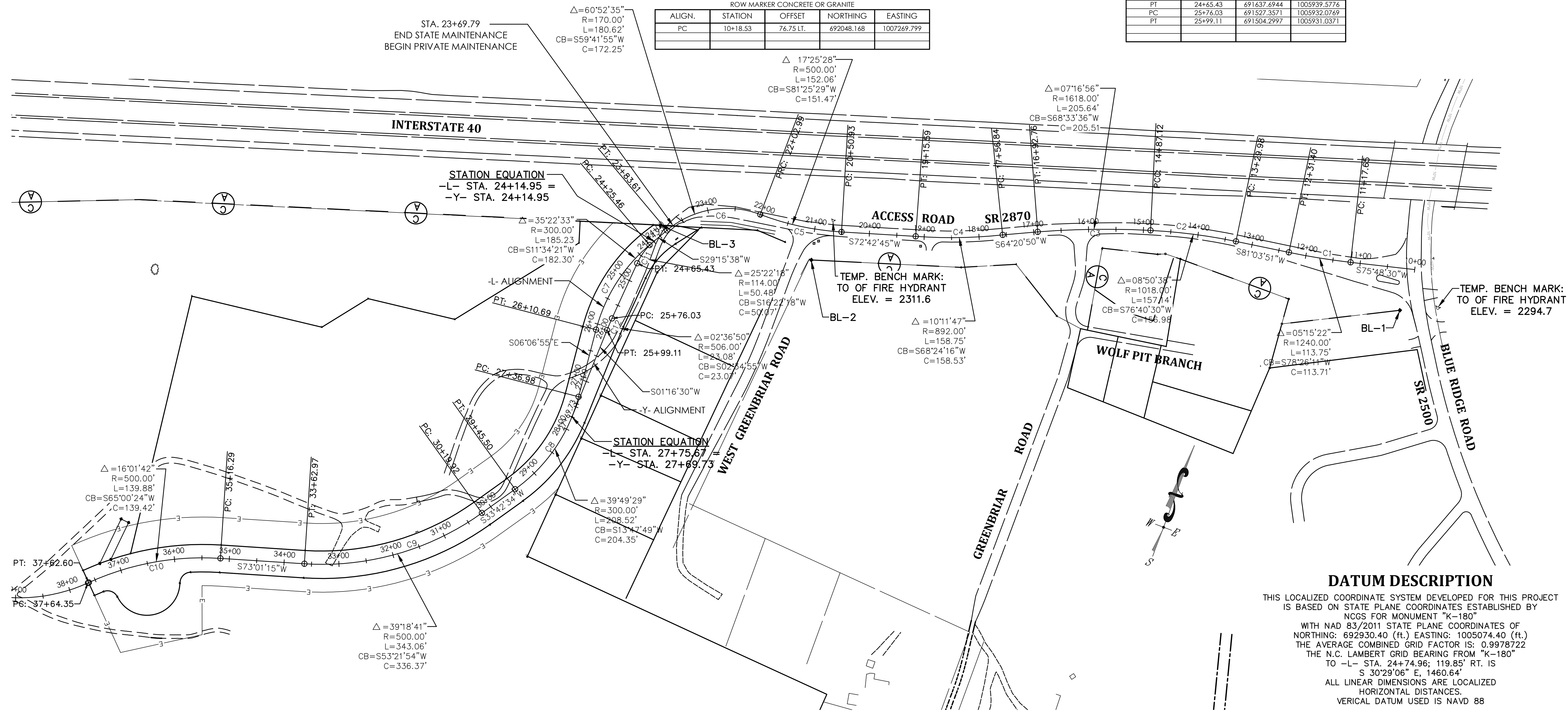

### DATUM DESCRIPTION

THIS LOCALIZED COORDINATE SYSTEM DEVELOPED FOR THIS PROJECT IS BASED ON STATE PLANE COORDINATES ESTABLISHED BY NCGS FOR MONUMENT "K-180" WITH NAD 83/2011 STATE PLANE COORDINATES OF NORTHING: 692930.40 (ft.) EASTING: 1005074.40 (ft.) THE AVERAGE COMBINED GRID FACTOR IS: 0.9978722 THE N.C. LAMBERT GRID BEARING FROM "K-180" TO -L- STA. 24+74.96; 119.85' RT. IS S 30°29'06" E, 1460.64' ALL LINEAR DIMENSIONS ARE LOCALIZED HORIZONTAL DISTANCES. VERTICAL DATUM USED IS NAVD 88



**PAVEMENT SCHEDULE**

C1	PROP. 1.5" ASPHALT CONCRETE SURFACE COURSE, TYPE S9.5C AT AN AVERAGE RATE OF 168 LBS. PER SQ. YD.
C2	PROP. 3" ASPHALT CONCRETE SURFACE COURSE, TYPE S9.5C AT AN AVERAGE RATE OF 168 LBS. PER SQ. YD. (1.5" IN EACH OF TWO LAYERS)
D1	PROP. 4" ASPHALT CONCRETE INTERMEDIATE COURSE, TYPE I19.0C AT AN AVERAGE RATE OF 456 LBS. PER SQ. YD.
E1	PROP. 4" ASPHALT CONCRETE BASE COURSE, TYPE B25.0C AT AN AVERAGE RATE OF 456 LBS. PER SQ. YD.
R1	2'-6" CONC CURB & GUTTER
R2	2'-6" CONC CURB & GUTTER (REVERSE GUTTER PAN)
T	PROP. SHOULDER RECONSTRUCTION
U	EXISTING PAVEMENT

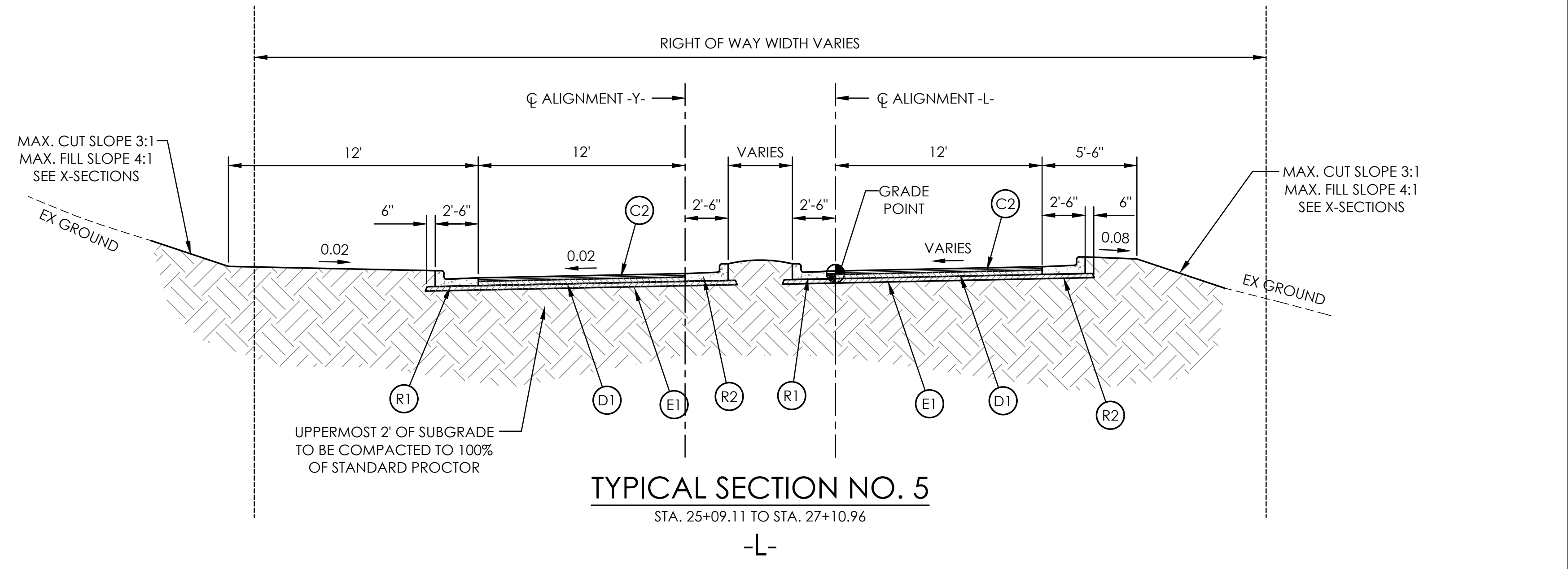
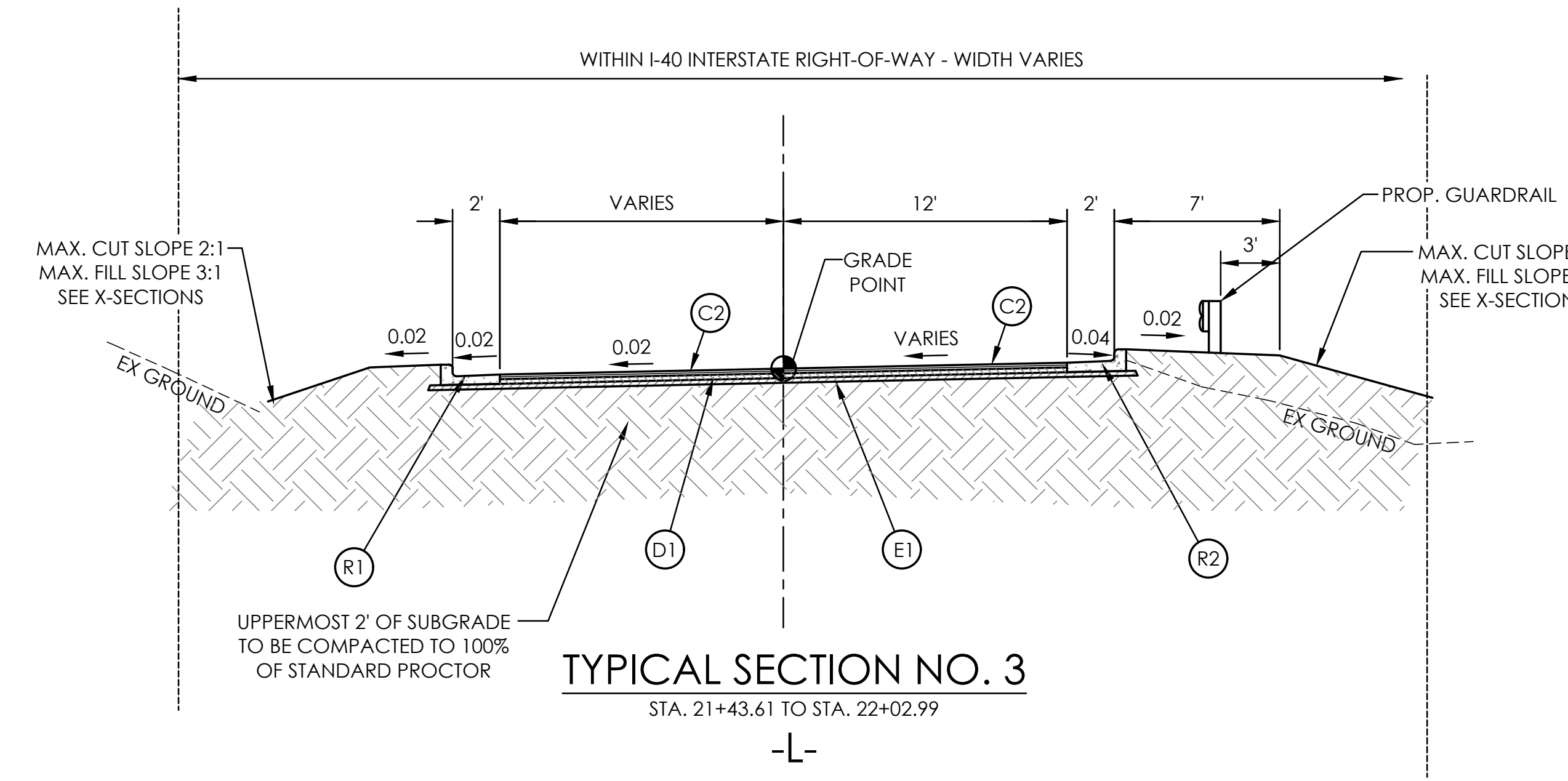
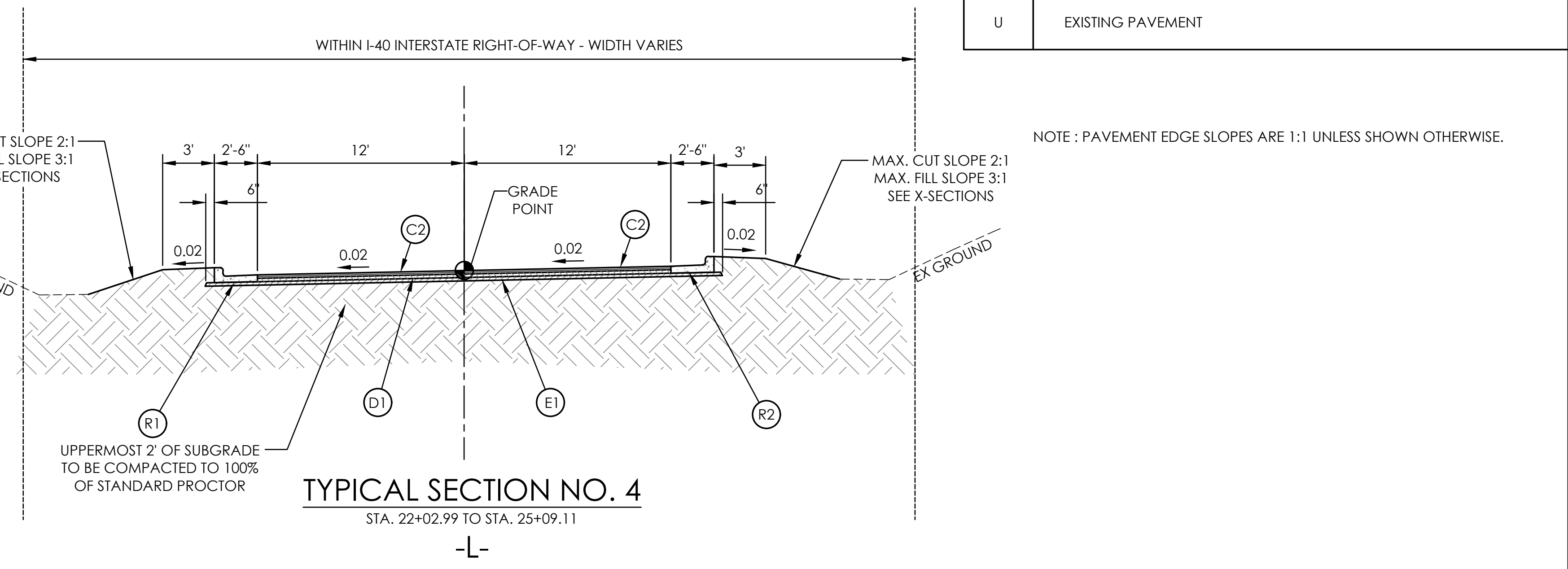
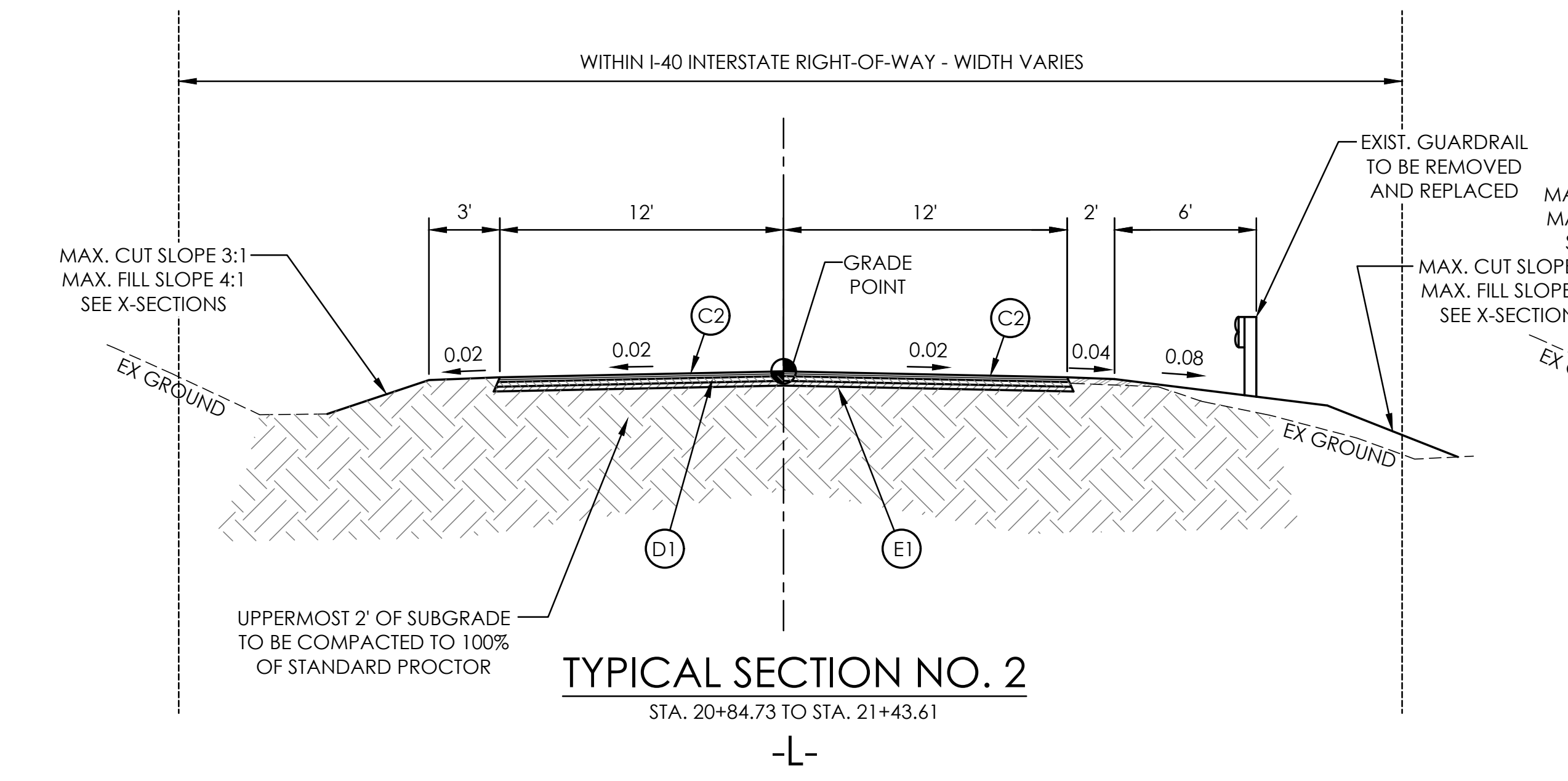
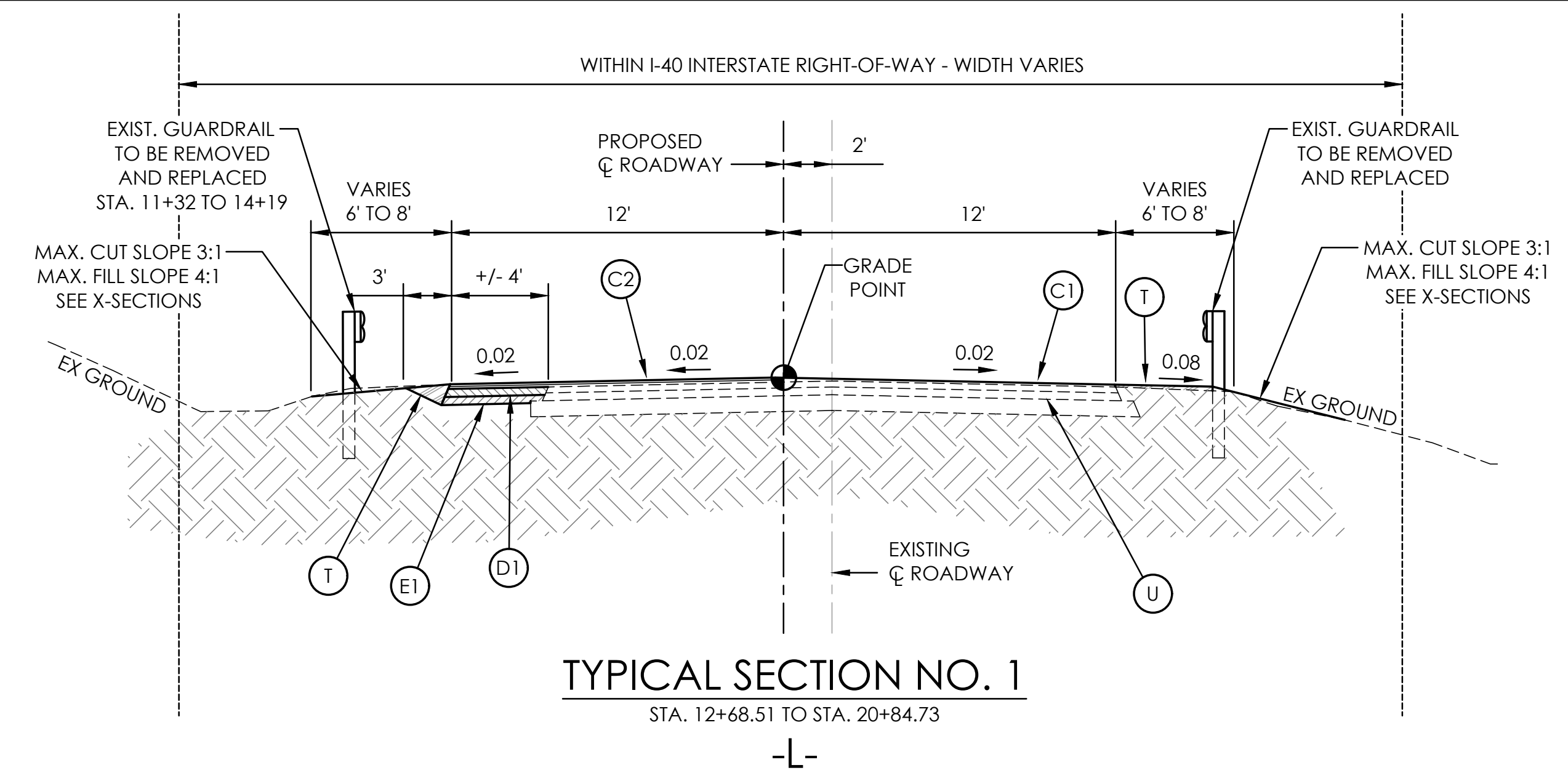

NOTE: PAVEMENT EDGE SLOPES ARE 1:1 UNLESS SHOWN OTHERWISE.

### PAVEMENT SCHEDULE

C1	PROP. 1.5" ASPHALT CONCRETE SURFACE COURSE, TYPE S9.5C AT AN AVERAGE RATE OF 168 LBS. PER SQ. YD.
C2	PROP. 3" ASPHALT CONCRETE SURFACE COURSE, TYPE S9.5C AT AN AVERAGE RATE OF 168 LBS. PER SQ. YD. (1.5" IN EACH OF TWO LAYERS)
D1	PROP. 4" ASPHALT CONCRETE INTERMEDIATE COURSE, TYPE I19.0B AT AN AVERAGE RATE OF 456 LBS. PER SQ. YD.
E1	PROP. 4" ASPHALT CONCRETE BASE COURSE, TYPE B25.0B AT AN AVERAGE RATE OF 456 LBS. PER SQ. YD.
R1	2'-6" CONC CURB & GUTTER
R2	2'-6" CONC CURB & GUTTER (REVERSE UTTER PAN)
T	PROP. SHOULDER RECONSTRUCTION
U	EXISTING PAVEMENT

NOTE: PAVEMENT EDGE SLOPES ARE 1:1 UNLESS SHOWN OTHERWISE.

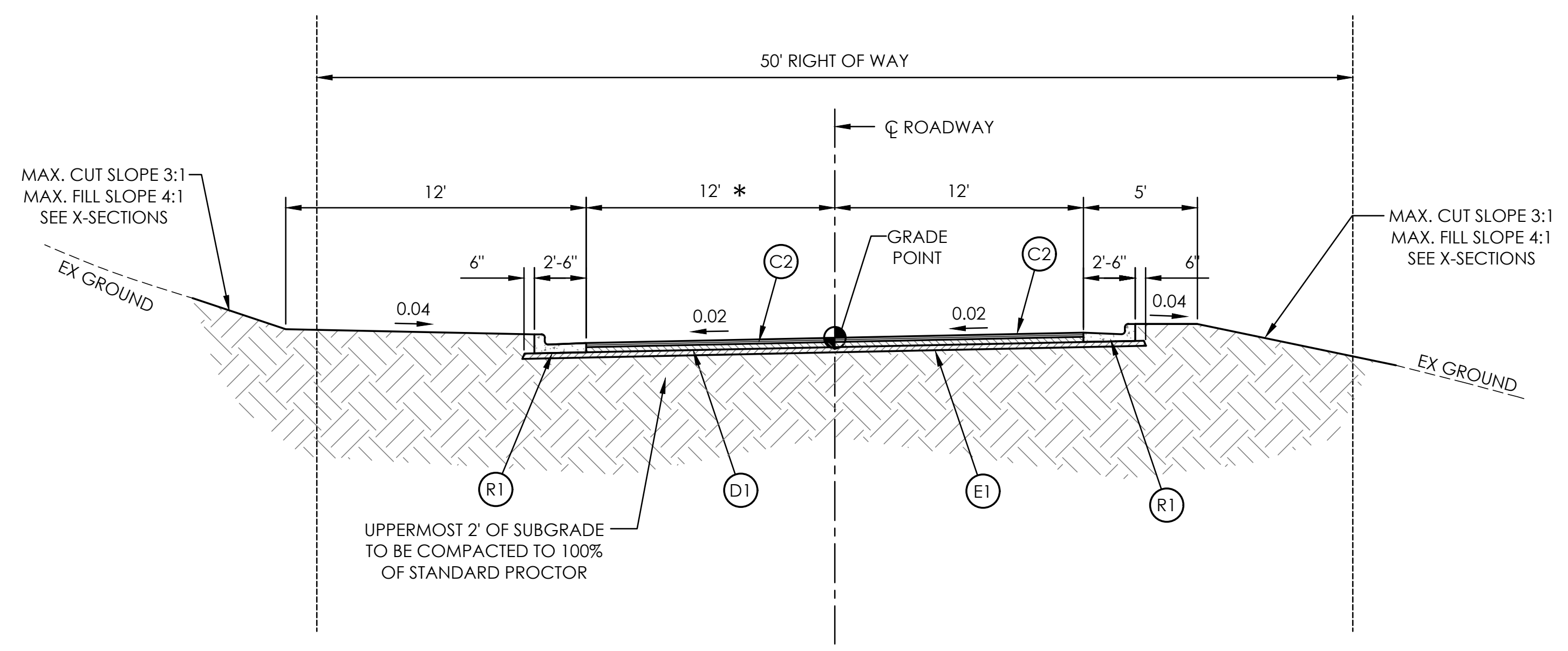

**TYPICAL SECTION NO. 6**  
 \* - WIDTH VARIES FROM  
 STA. 23+58.50 TO STA. 25+03.38  
 AND STA. 27+07.30 TO STA. 27+70.08  
 STA. 27+10.96 TO STA. 35+88.56  
 STA. 37+27.64 TO STA. 37+40.00

-L-

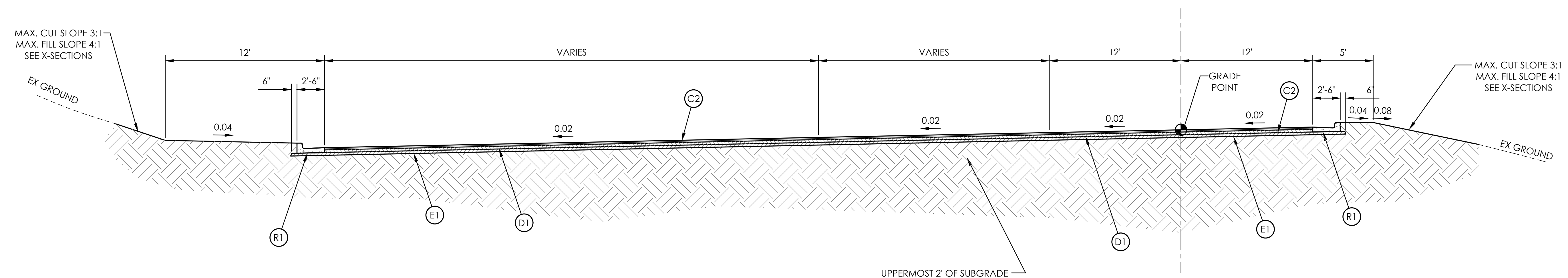

**TYPICAL SECTION NO. 7**  
 STA. 35+88.56 TO STA. 37+27.64

-L-







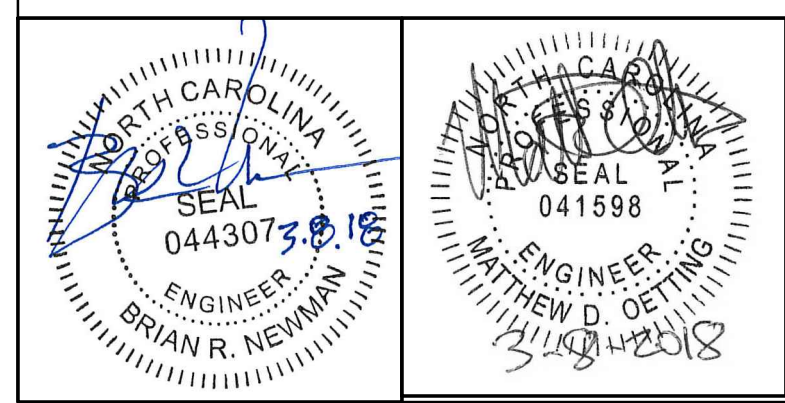

CURVE	RADIUS	LENGTH	CHORD BEARING	CHORD	DELTA	TANGENT
C1	1240.00'	113.75'	S78°26'11"W	113.71'	05°15'22"	56.92'
C2	1018.00'	157.14'	S76°40'30"W	156.98'	08°50'38"	78.72'
C3	1618.00'	205.64'	S68°33'06"W	205.51'	07°16'56"	102.96'
C4	892.00'	158.75'	S68°24'16"W	158.53'	10°11'47"	79.58'
C5	500.00'	152.06'	S81°25'29"W	151.47'	17°25'28"	76.62'
C6	170.00'	180.62'	S59°41'55"W	172.25'	60°52'35"	98.89'
C7	300.00'	185.23'	S11°34'21"W	287.90'	35°22'33"	95.67'
C8	300.00'	208.52'	S13°47'49"W	204.35'	39°49'29"	108.67'
C9	500.00'	343.06'	S53°21'54"W	336.37'	39°18'41"	178.59'
C10	500.00'	139.88'	S65°00'24"W	139.42'	16°01'42"	70.40'

FMD REAL ESTATE, LLC  
D.B. 4803, PG. 538  
P.B. 7, PG. 8

SISTERHOOD REAL ESTATE, LLC  
D.B. 5463, PG. 83  
P.B. 7, PG. 8

DOUGLAS M. BROCK  
D.B. 3983, PG. 879  
P.B. 7, PG. 8

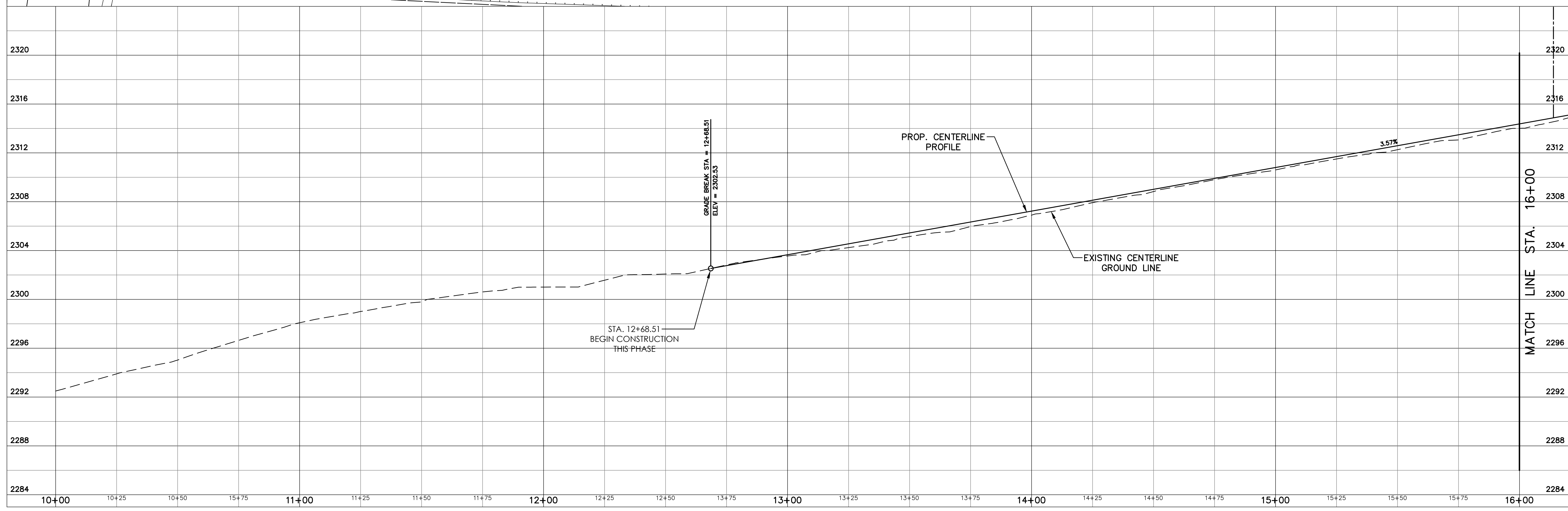
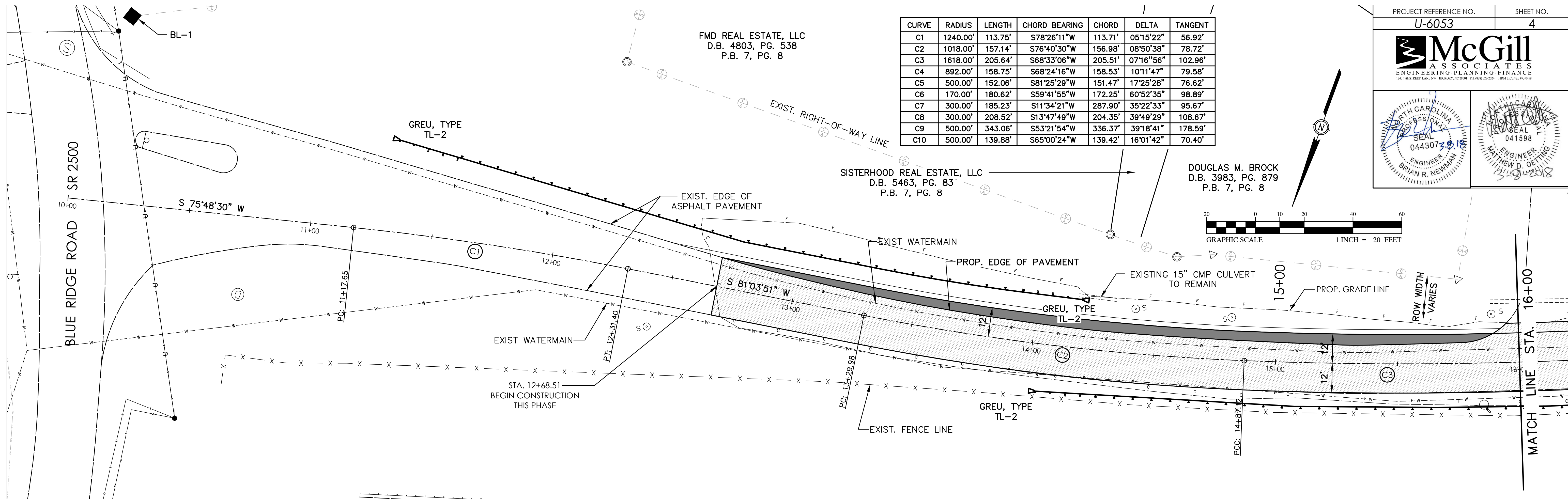
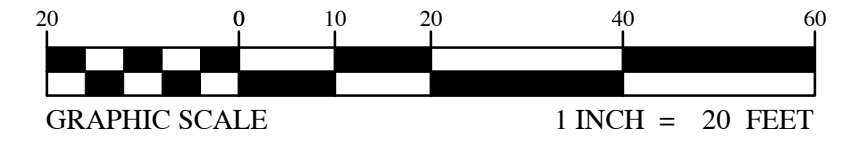

RICHARD A. MCGINNIS  
D.B. 5265, PG. 1253  
P.B. 177, PG. 43

JULIO EDUARDO SCHULZ  
D.B. 4420, PG. 537  
P.B. 7, PG. 8

ARTHUR F. HOLMAN, JR.  
KATHERINE E. HOLMAN  
D.B. 4733, PG. 1309

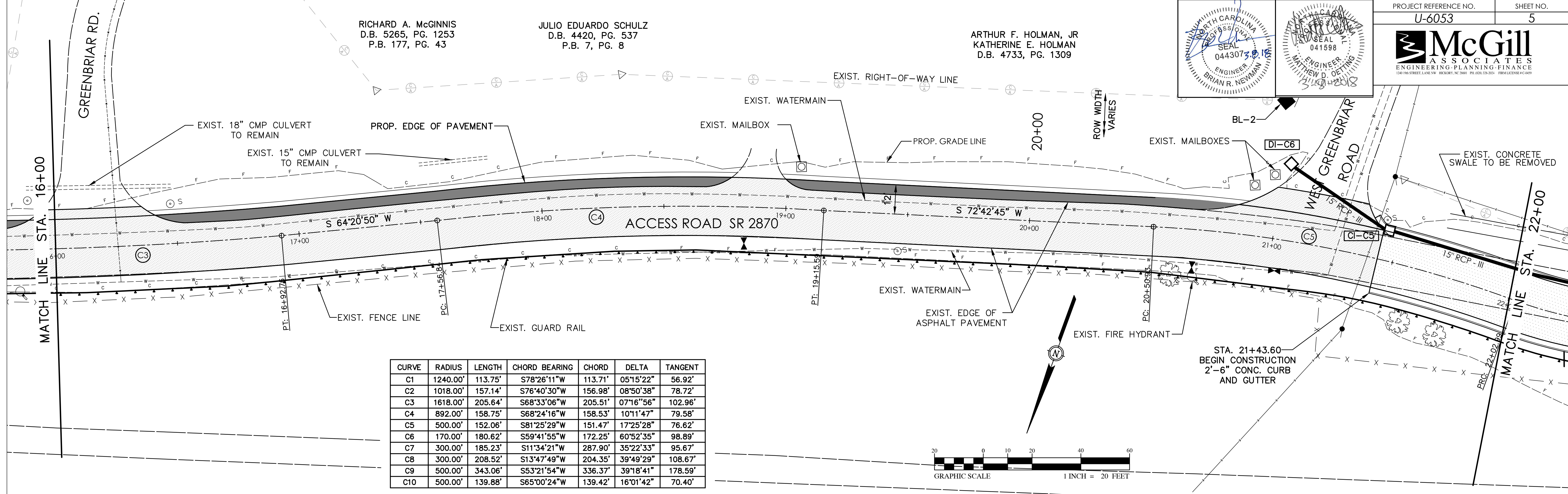
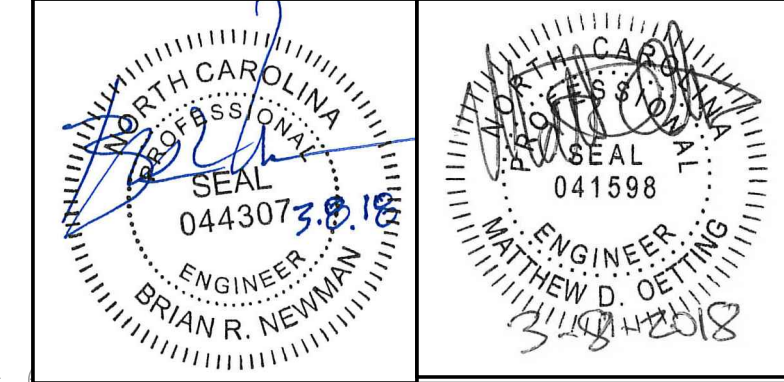

CURVE	RADIUS	LENGTH	CHORD BEARING	CHORD	DELTA	TANGENT
C1	1240.00'	113.75'	S78°26'11"W	113.71'	05°15'22"	56.92'
C2	1018.00'	157.14'	S76°40'30"W	156.98'	08°50'38"	78.72'
C3	1618.00'	205.64'	S68°33'06"W	205.51'	07°16'56"	102.96'
C4	892.00'	158.75'	S68°24'16"W	158.53'	10°11'47"	79.58'
C5	500.00'	152.06'	S81°25'29"W	151.47'	17°25'28"	76.62'
C6	170.00'	180.62'	S59°41'55"W	172.25'	60°52'35"	98.89'
C7	300.00'	185.23'	S11°34'21"W	287.90'	35°22'33"	95.67'
C8	300.00'	208.52'	S13°47'49"W	204.35'	39°49'29"	108.67'
C9	500.00'	343.06'	S53°21'54"W	336.37'	39°18'41"	178.59'
C10	500.00'	139.88'	S65°00'24"W	139.42'	16°01'42"	70.40'

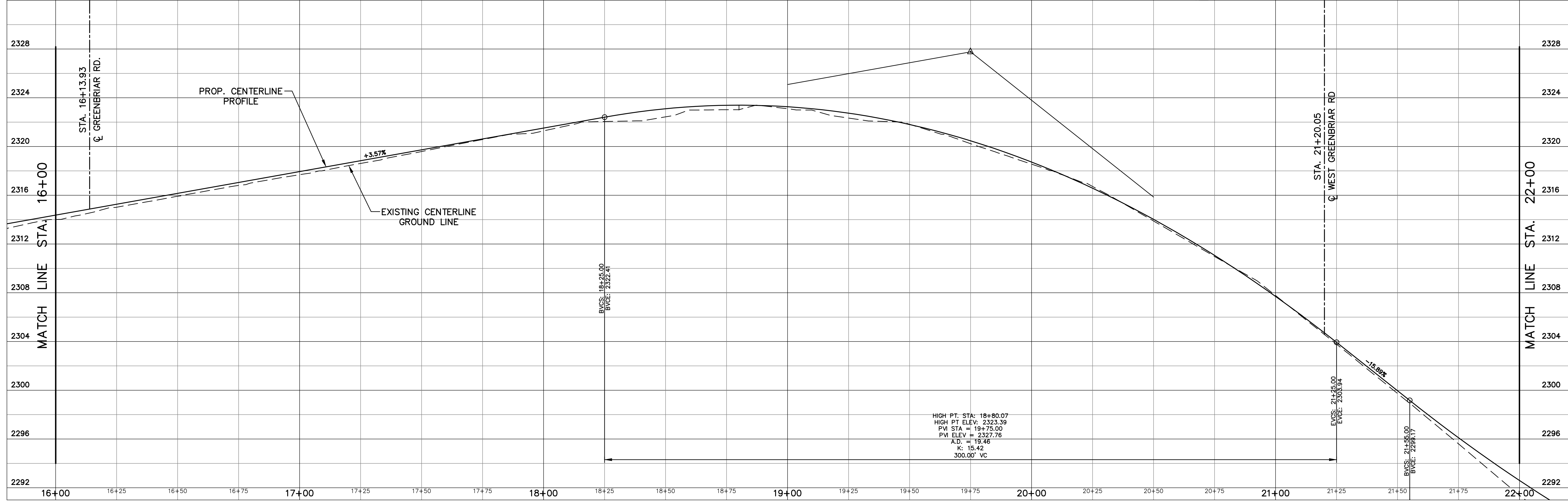

BORNER  
 D.B. 2037, PG. 85

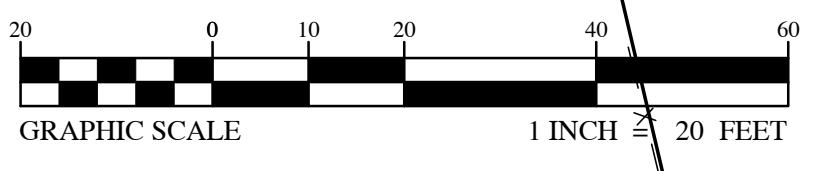

LINE -L- CURVE TABLE

CURVE	RADIUS	LENGTH	CHORD BEARING	CHORD	DELTA	TANGENT
C1	1240.00'	113.75'	S78°26'11"W	113.71'	05°15'22"	56.92'
C2	1018.00'	157.14'	S76°40'30"W	156.98'	08°50'38"	78.72'
C3	1618.00'	205.64'	S68°33'06"W	205.51'	07°16'56"	102.96'
C4	892.00'	158.75'	S68°24'16"W	158.53'	10°11'47"	79.58'
C5	500.00'	152.06'	S81°25'29"W	151.47'	17°25'28"	76.62'
C6	170.00'	180.62'	S59°41'55"W	172.25'	60°52'35"	98.89'
C7	300.00'	185.23'	S11°34'21"W	287.90'	35°22'33"	95.67'
C8	300.00'	208.52'	S13°47'49"W	204.35'	39°49'29"	108.67'
C9	500.00'	343.06'	S53°21'54"W	336.37'	39°18'41"	178.59'
C10	500.00'	139.88'	S65°00'24"W	139.42'	16°01'42"	70.40'

LINE -Y- CURVE TABLE

CURVE	RADIUS	LENGTH	CHORD BEARING	CHORD	DELTA	TANGENT
C11	114.00'	50.48'	S16°22'18"W	50.07'	25°22'18"	25.66'
C12	506.00'	23.08'	S02°34'55"W	23.07'	02°36'50"	11.54'

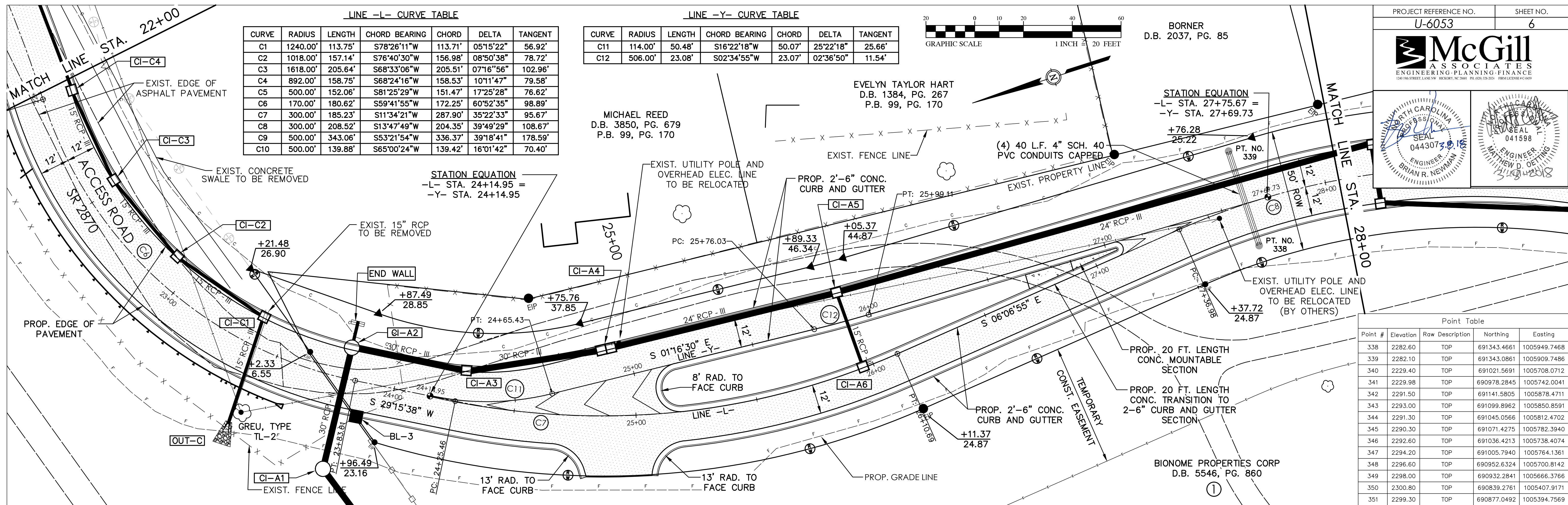

STATION EQUATION  
 -L- STA. 24+14.95 =  
 -Y- STA. 24+14.95

STATION EQUATION  
 -L- STA. 27+75.67 =  
 -Y- STA. 27+69.73

Point Table

Point #	Elevation	Row Description	Northing	Easting
338	2282.60	TOP	691343.4661	1005949.7468
339	2282.10	TOP	691343.0861	1005909.7486
340	2229.40	TOP	691021.5691	1005708.0712
341	2229.98	TOP	690978.2845	1005742.0041
342	2291.50	TOP	691141.5805	1005878.4711
343	2293.00	TOP	691099.8962	1005850.8591
344	2291.30	TOP	691045.0566	1005812.4702
345	2290.30	TOP	691071.4275	1005782.3940
346	2292.60	TOP	691036.4213	1005738.4074
347	2294.20	TOP	691005.7940	1005764.1361
348	2296.60	TOP	690952.6324	1005700.8142
349	2298.00	TOP	690932.2841	1005666.3766
350	2300.80	TOP	690839.2761	1005407.9171
351	2299.30	TOP	690877.0492	1005394.7569

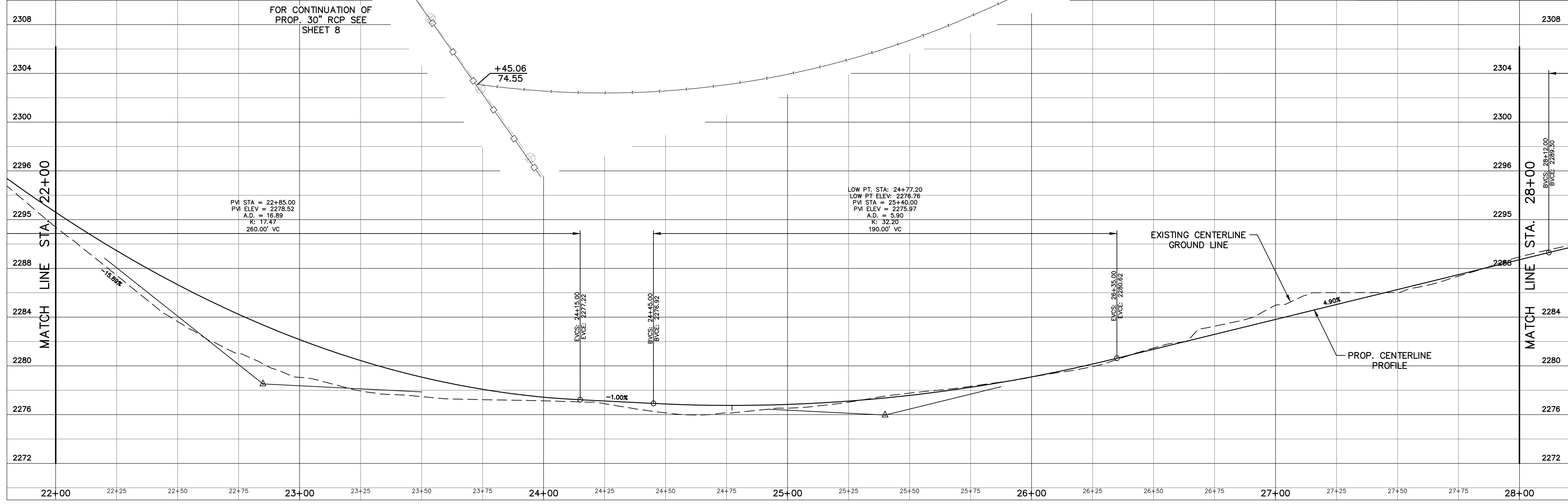

PVI STA = 22+85.00  
 PVI ELEV = 2278.52  
 A.D. = 16.89  
 K = 17.47  
 260.00' VC

LOW PT. STA: 24+77.20  
 LOW PT. ELEV: 2276.76  
 PVI STA = 25+40.00  
 PVI ELEV = 2275.97  
 A.D. = 5.90  
 K = 32.20  
 190.00' VC

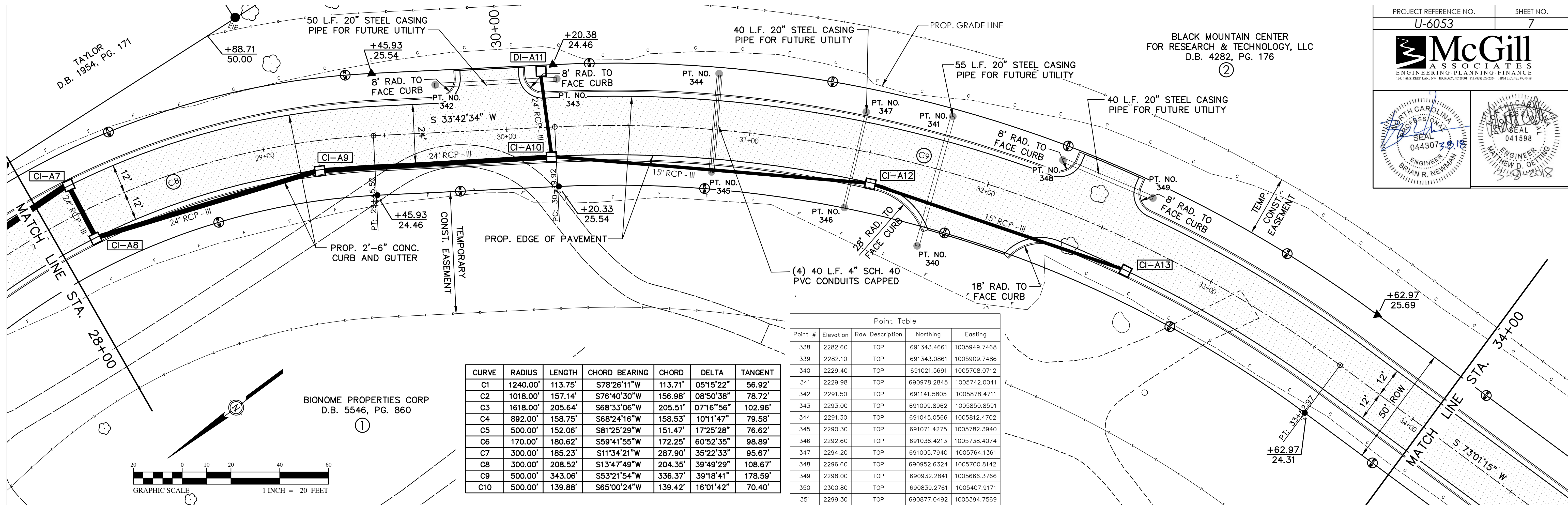
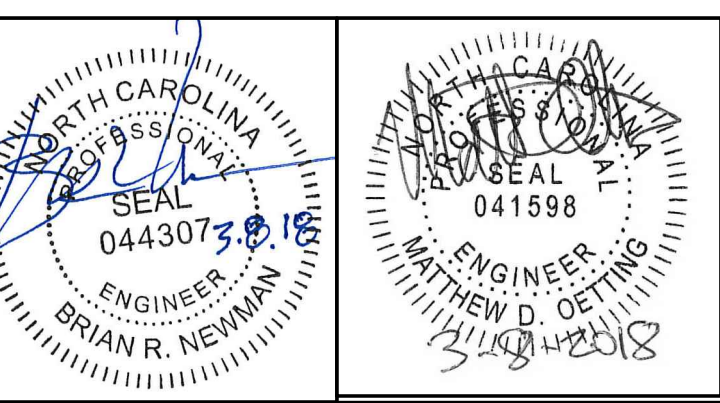

CURVE	RADIUS	LENGTH	CHORD BEARING	CHORD	DELTA	TANGENT
C1	1240.00'	113.75'	S78°26'11\"W	113.71'	05°15'22\"	56.92'
C2	1018.00'	157.14'	S76°40'30\"W	156.98'	08°50'38\"	78.72'
C3	1618.00'	205.64'	S68°33'06\"W	205.51'	07°16'56\"	102.96'
C4	892.00'	158.75'	S68°24'16\"W	158.53'	10°11'47\"	79.58'
C5	500.00'	152.06'	S81°25'29\"W	151.47'	17°25'28\"	76.62'
C6	170.00'	180.62'	S59°41'55\"W	172.25'	60°52'35\"	98.89'
C7	300.00'	185.23'	S11°34'21\"W	287.90'	35°22'33\"	95.67'
C8	300.00'	208.52'	S13°47'49\"W	204.35'	39°49'29\"	108.67'
C9	500.00'	343.06'	S53°21'54\"W	336.37'	39°18'41\"	178.59'
C10	500.00'	139.88'	S65°00'24\"W	139.42'	16°01'42\"	70.40'

Point #	Elevation	Raw Description	Northing	Easting
338	2282.60	TOP	691343.4661	1005949.7468
339	2282.10	TOP	691343.0861	1005909.7486
340	2229.40	TOP	691021.5691	1005708.0712
341	2229.98	TOP	690978.2845	1005742.0041
342	2291.50	TOP	691141.5805	1005878.4711
343	2293.00	TOP	691099.8962	1005850.8591
344	2291.30	TOP	691045.0566	1005812.4702
345	2290.30	TOP	691071.4275	1005782.3940
346	2292.60	TOP	691036.4213	1005738.4074
347	2294.20	TOP	691005.7940	1005764.1361
348	2296.60	TOP	690952.6324	1005700.8142
349	2298.00	TOP	690932.2841	1005666.3766
350	2300.80	TOP	690839.2761	1005407.9171
351	2299.30	TOP	690877.0492	1005394.7569

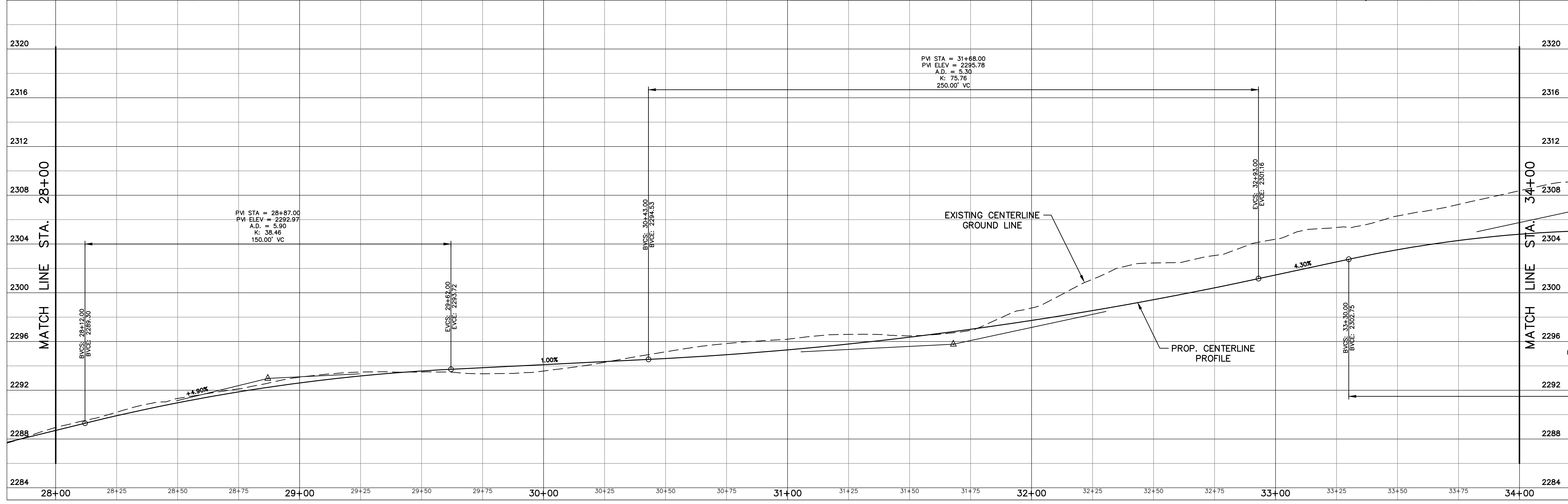

CURVE	RADIUS	LENGTH	CHORD BEARING	CHORD	DELTA	TANGENT
C1	1240.00'	113.75'	S78°26'11"W	113.71'	05°15'22"	56.92'
C2	1018.00'	157.14'	S76°40'30"W	156.98'	08°50'38"	78.72'
C3	1618.00'	205.64'	S68°33'06"W	205.51'	07°16'56"	102.96'
C4	892.00'	158.75'	S68°24'16"W	158.53'	10°11'47"	79.58'
C5	500.00'	152.06'	S81°25'29"W	151.47'	17°25'28"	76.62'
C6	170.00'	180.62'	S59°41'55"W	172.25'	60°52'35"	98.89'
C7	300.00'	185.23'	S11°34'21"W	287.90'	35°22'33"	95.67'
C8	300.00'	208.52'	S13°47'49"W	204.35'	39°49'29"	108.67'
C9	500.00'	343.06'	S53°21'54"W	336.37'	39°18'41"	178.59'
C10	500.00'	139.88'	S65°00'24"W	139.42'	16°01'42"	70.40'

PROJECT REFERENCE NO. U-6053 SHEET NO. 8

**McGill ASSOCIATES**  
ENGINEERING-PLANNING-FINANCE

SEAL  
0443073  
ENGINEER  
BRIAN R. NEWMAN

SEAL  
041598  
ENGINEER  
MATTHEW D. GETTING

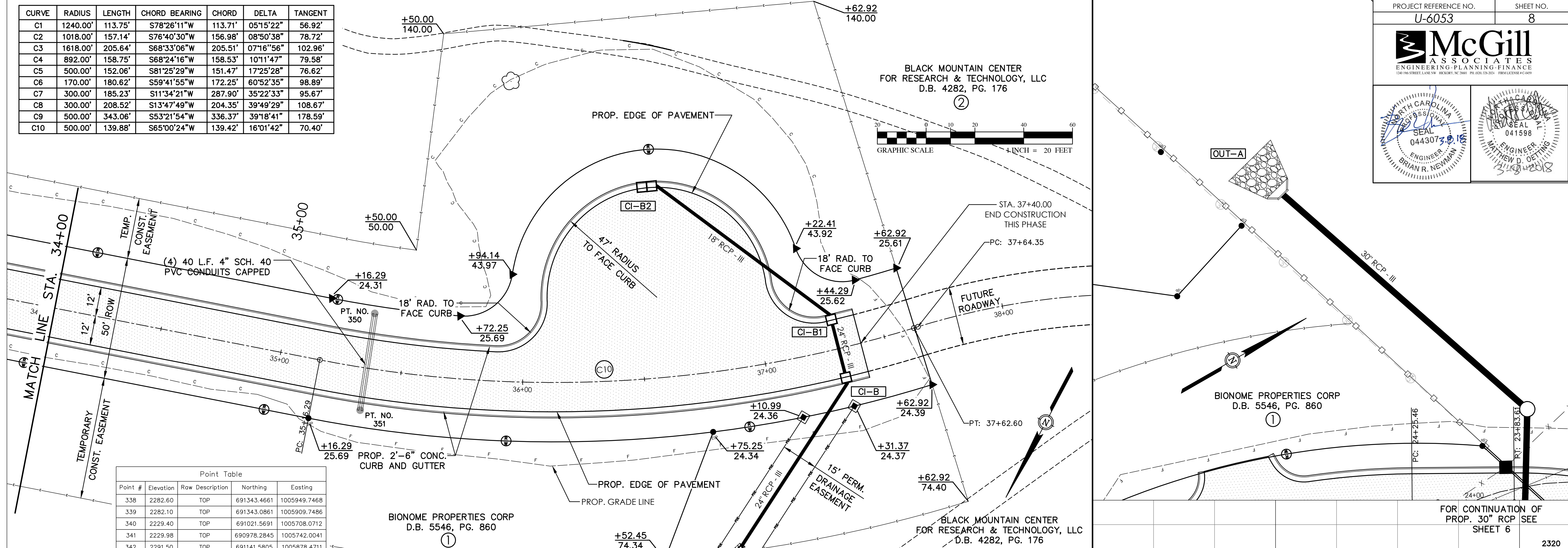

Point Table

Point #	Elevation	Raw Description	Northing	Easting
338	2282.60	TOP	691343.4661	1005949.7468
339	2282.10	TOP	691343.0861	1005909.7486
340	2229.40	TOP	691021.5691	1005708.0712
341	2229.98	TOP	690978.2845	1005742.0041
342	2291.50	TOP	691141.5805	1005878.4711
343	2293.00	TOP	691099.8962	1005850.8591
344	2291.30	TOP	691045.0566	1005812.4702
345	2290.30	TOP	691071.4275	1005782.3940
346	2292.60	TOP	691036.4213	1005738.4074
347	2294.20	TOP	691005.7940	1005764.1361
348	2296.60	TOP	690952.6324	1005700.8142
349	2298.00	TOP	690932.2841	1005666.3766
350	2300.80	TOP	690839.2761	1005407.9171
351	2299.30	TOP	690877.0492	1005394.7569

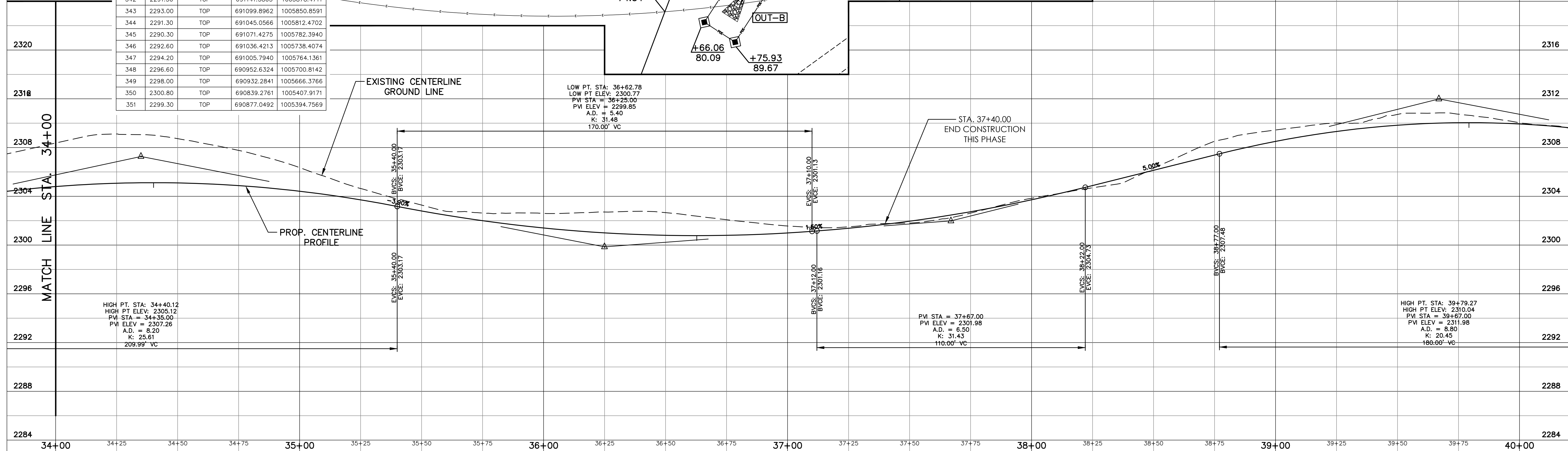

FOR CONTINUATION OF  
PROP. 30" RCP SEE  
SHEET 6

2320  
2316  
2312  
2308  
2304  
2300  
2296  
2292  
2288  
2284



## STANDARD DRAWINGS

THE FOLLOWING ROADWAY STANDARDS AS SHOWN IN "STANDARD DRAWINGS" - PROJECT SERVICES UNIT - N.C. DEPARTMENT OF TRANSPORTATION - RALEIGH, N.C., DATED JANUARY 2018 ARE APPLICABLE TO THIS PROJECT AND BY REFERENCE HEREBY ARE CONSIDERED A PART OF THESE PLANS:

STD. NO.	TITLE
1101.02	TEMPORARY LANE CLOSURES
1101.11	2-LANE - 2-WAY ROADWAY - 1 LANE CLOSURE
1145.01	TRAFFIC CONTROL DESIGN TABLES
1150.01	BARRICADES - TYPE III
1180.01	FLAGGING DEVICES
1205.01	SKINNY DRUMS
1205.01	PAVEMENT MARKINGS - LINE TYPES & OFFSETS
1205.04	PAVEMENT MARKINGS - INTERSECTIONS

## TRANSPORTATION OPERATIONS

WIDENING OF EXISTING ROADWAY AND OVERLAY OF EXISTING ROADWAY AND WIDENING AS SHOWN IN THE CONSTRUCTION PLANS.

## LOCAL NOTES

NOTIFY BUNCOMBE COUNTY EMERGENCY SERVICES AND PUBLIC SCHOOL AT LEAST ONE MONTH PRIOR TO LANE CLOSURE.

## GENERAL NOTES

CHANGES MAY BE REQUIRED WHEN PHYSICAL DIMENSIONS IN THE DETAIL DRAWINGS, STANDARD DETAILS AND ROADWAY DETAILS ARE NOT ATTAINABLE TO MEET FIELD CONDITIONS, OR RESULT IN DUPLICATE, OR UNDESIRABLE OVERLAPPING OF DEVICES. MODIFICATIONS MAY INCLUDE, SUPPLEMENTING, COVERING OR REMOVAL OF DEVICES, AS DIRECTED BY THE ENGINEER.

THE FOLLOWING GENERAL NOTES APPLY AT ALL TIMES FOR THE DURATION OF THE CONSTRUCTION PROJECT, EXCEPT WHEN OTHERWISE NOTED IN THE PLAN, OR AS DIRECTED BY THE ENGINEER.

**TRAFFIC PATTERN ALTERATIONS**  
A) NOTIFY THE ENGINEER TWENTY ONE (21) DAYS PRIOR TO ANY TRAFFIC PATTERN ALTERATION.

**SIGNING**  
B) PROVIDE TEMPORARY SIGNING.

C) PROVIDE SIGNING AND DEVICES REQUIRED TO CLOSE THE ROADWAY LANE ACCORDING TO THE ROADWAY STANDARD DRAWINGS AND TRAFFIC CONTROL PLANS.

D) COVER OR REMOVE ALL SIGNS AND DEVICES TO CLOSE LANE WHEN LANE CLOSURE IS NOT IN OPERATION. LANE CLOSURE NOT TO BE PERMITTED OVER NIGHT.

E) ENSURE ALL NECESSARY SIGNING IS IN PLACE PRIOR TO ALTERING ANY TRAFFIC PATTERN.

**TRAFFIC CONTROL DEVICES**  
F) PLACE TYPE III BARRICADE WITH "ROAD CLOSED" SIGN R-11-2 ATTACHED AS SHOWN ON THE TRAFFIC CONTROL PLAN.

**PAVEMENT MARKINGS AND MARKERS**  
G) INSTALL PAVEMENT MARKING (PAINT) ON THE FINAL SURFACE OF THE ENTIRE PROJECT.

H) TIE PROPOSED PAVEMENT MARKING LINES TO EXISTING PAVEMENT MARKING LINES.

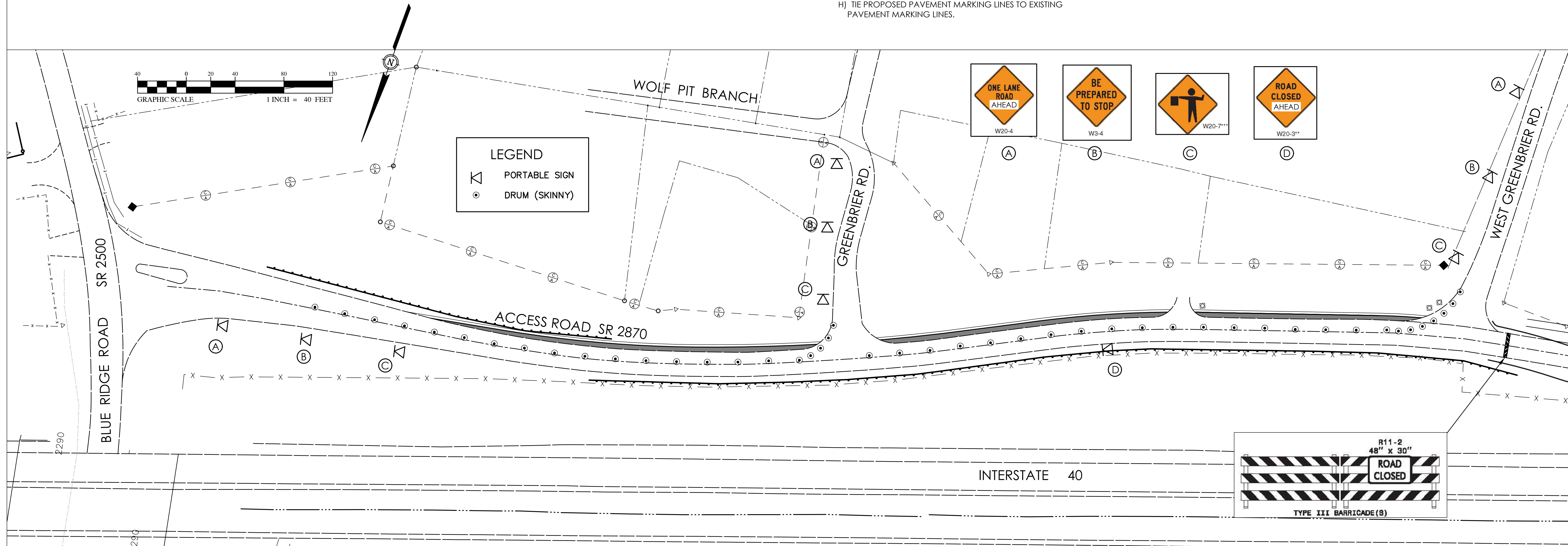

TIP PROJECT: U-6053

CONTRACT:

STATE OF NORTH CAROLINA  
DIVISION OF HIGHWAYS

**BUNCOMBE COUNTY**

**PAVEMENT MARKING PLAN**

PROJECT REFERENCE NO. U-6053	SHEET NO. PMP-1
---------------------------------	--------------------

**McGill**  
ASSOCIATES  
ENGINEERING-PLANNING-FINANCE  
1200 19th STREET, LANE SW HICKORY, NC 28601 PH: (820) 320-2024 FAX: LICENSE # C-6499

**ROADWAY STANDARD DRAWINGS**

The following Roadway Standards appear in "Roadway Standard Drawings" Highway Design Branch - N.C. Department of Transportation - Raleigh, N.C., Dated January, 2018 are applicable to this project and by reference hereby are considered a part of these plans:

STD. NO.	TITLE
1205.01	PAVEMENT MARKINGS - LINE TYPES AND OFFSETS
1205.02	PAVEMENT MARKINGS - 2 LANE AND MULTILANE ROADS
1205.04	PAVEMENT MARKINGS - INTERSECTIONS
1205.09	PAVEMENT MARKINGS - MEDIAN ISLAND SEPARATING TRAFFIC IN OPPOSING DIRECTION
1261.01	GUARDRAIL AND BARRIER DELINEATOR SPACING
1261.02	GUARDRAIL AND BARRIER DELINEATOR TYPES
1262.01	GUARDRAIL END DELINATION

**SHEET INDEX**

SHEET. NO.	TITLE
PMP-1	PAVEMENT MARKING COVER SHEET AND PM SCHEDULE
PMP-2	PAVEMENT MARKINGS - STATION 10+00 - 22+00
PMP-3	PAVEMENT MARKINGS - STATION 22+00 - 34+00
PMP-4	PAVEMENT MARKINGS - STATION 34+00 - 37+40

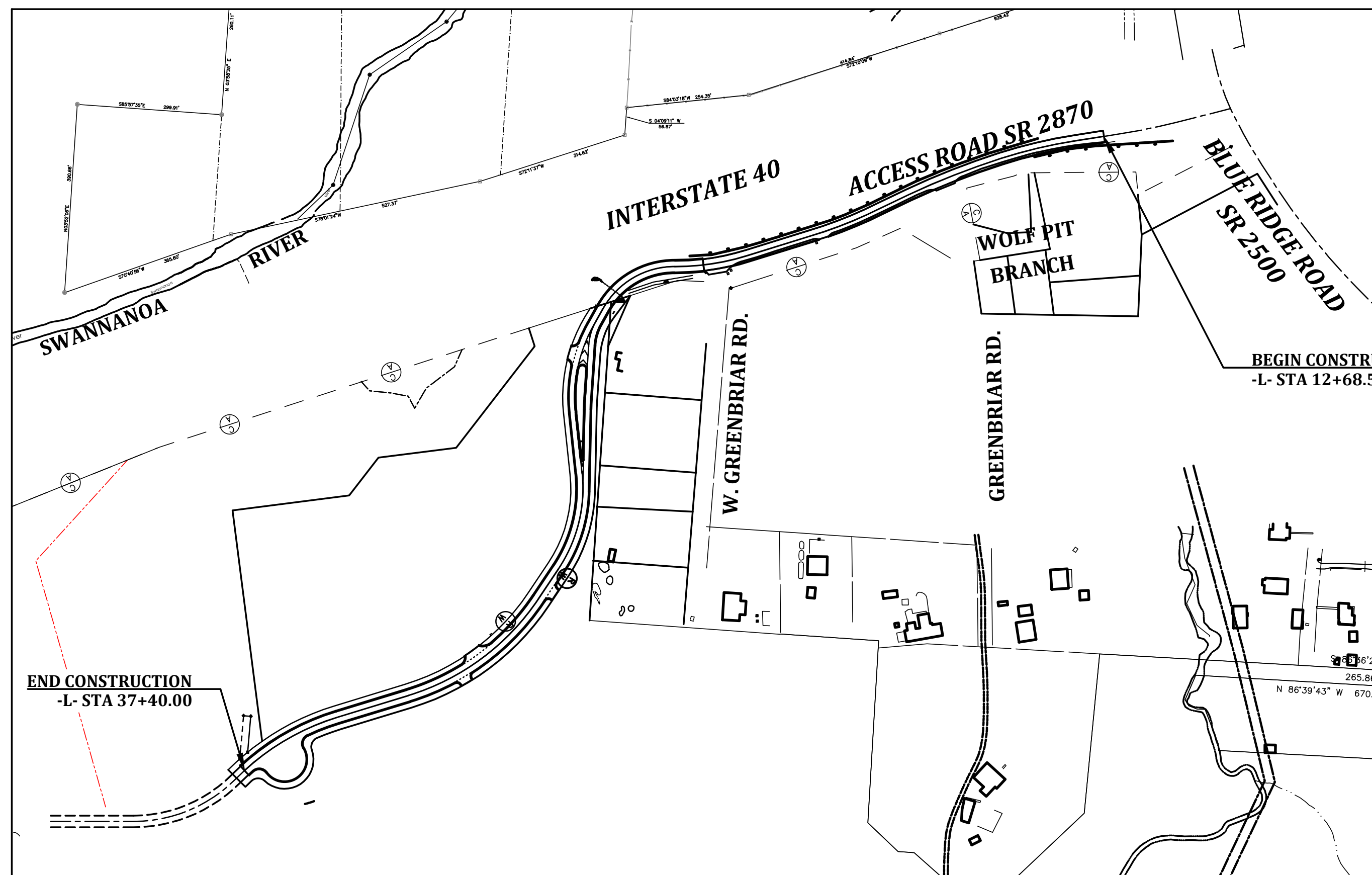
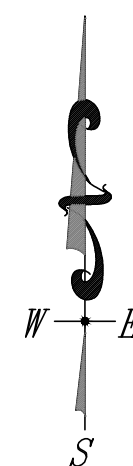

**GENERAL NOTES**

THE FOLLOWING GENERAL NOTES APPLY AT ALL TIMES FOR THE DURATION OF THE CONSTRUCTION PROJECT, EXCEPT WHEN OTHERWISE NOTED IN THE PLAN OR DIRECTED BY THE ENGINEER.

- A) INSTALL PAVEMENT MARKINGS AND PAVEMENT MARKERS ON THE FINAL SURFACE AS FOLLOWS:
 

ROAD NAME	MARKING PAINT
SR 2870 ACCESS ROAD	
- B) PLACE TWO (2) APPLICATIONS OF PAINT PAVEMENT MARKING ON THE FINAL WEARING SURFACE. PLACE THE SECOND APPLICATION OF PAINT UPON SUFFICIENT DRYING TIME OF THE FIRST.
- C) TIE PROPOSED PAVEMENT MARKING LINES TO EXISTING PAVEMENT MARKING LINES.
- D) REFER TO TRAFFIC CONTROL PLAN FOR PROJECT NOTES CONCERNING PAVEMENT MARKINGS, MARKERS, AND DELINATION.

**PAVEMENT MARKING SCHEDULE**

SYMBOL	DESCRIPTION
	FINAL PAVEMENT MARKINGS PAINT (2 APPLICATIONS EACH)
PA	WHITE EDGE LINE - 4"
PB	WHITE 2 FT - 6 FT MINI SKIP - 4"
PI	YELLOW DOUBLE CENTER - 4"
MI	YELLOW DIAGONAL - 8"

**GRAPHIC SCALES**

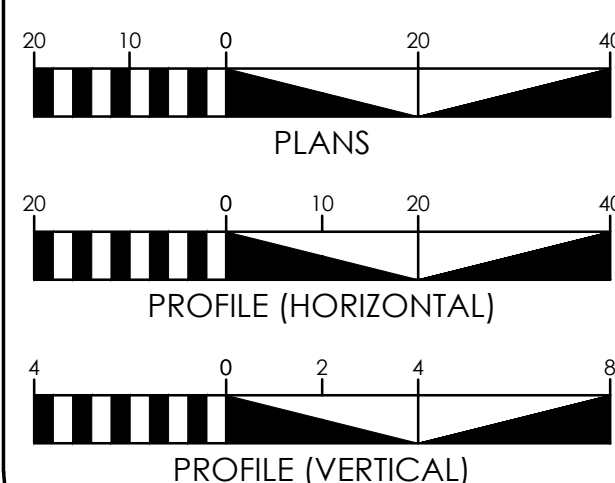

**DESIGN DATA**

ADT 2018 = 113  
ADT 2038 = 412  
K = \_\_\_  
D = \_\_\_  
T = \_\_\_  
V = 30 MPH  
FUNC CLASS = RURAL LOCAL

**PROJECT LENGTH**

LENGTH OF ROADWAY PROJECT U-6053 = 0.468 MILE  
LENGTH OF STRUCTURE PROJECT U-6053 = 0.000 MILE  
TOTAL LENGTH OF PROJECT U-6053 = 0.468 MILE

**PLANS PREPARED BY:**



2018 STANDARD SPECIFICATIONS	BRIAN R. NEWMAN, PE PROJECT ENGINEER
RIGHT OF WAY DATE:	
LETTING DATE: MAY 02, 2018	MATTHEW D. OETTING, PE PROJECT DESIGN ENGINEER

NCDOT CONTACT: TROY S. WILSON, PLS DIV 13 DISTRICT ENGINEER



**HYDRAULICS ENGINEER**

SIGNATURE:

**ROADWAY DESIGN ENGINEER**

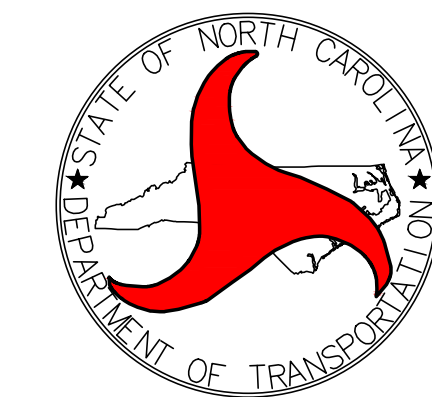
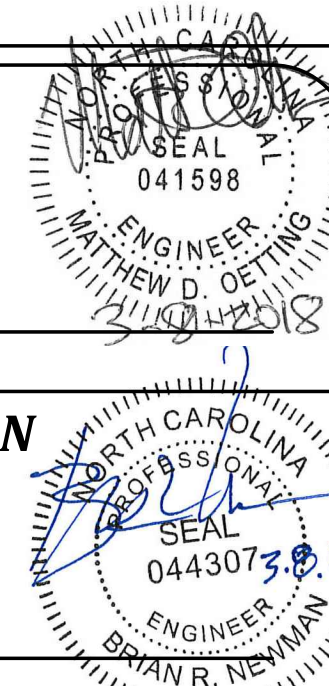
SIGNATURE:



PROJECT REFERENCE NO. U-6053	SHEET NO. PMP-2
 <b>McGill</b> ASSOCIATES ENGINEERING · PLANNING · FINANCE <small>100 W. STREET, LENOIR, N.C. 28751 TEL: (828) 753-2200 FAX: (828) 753-4000</small>	
	

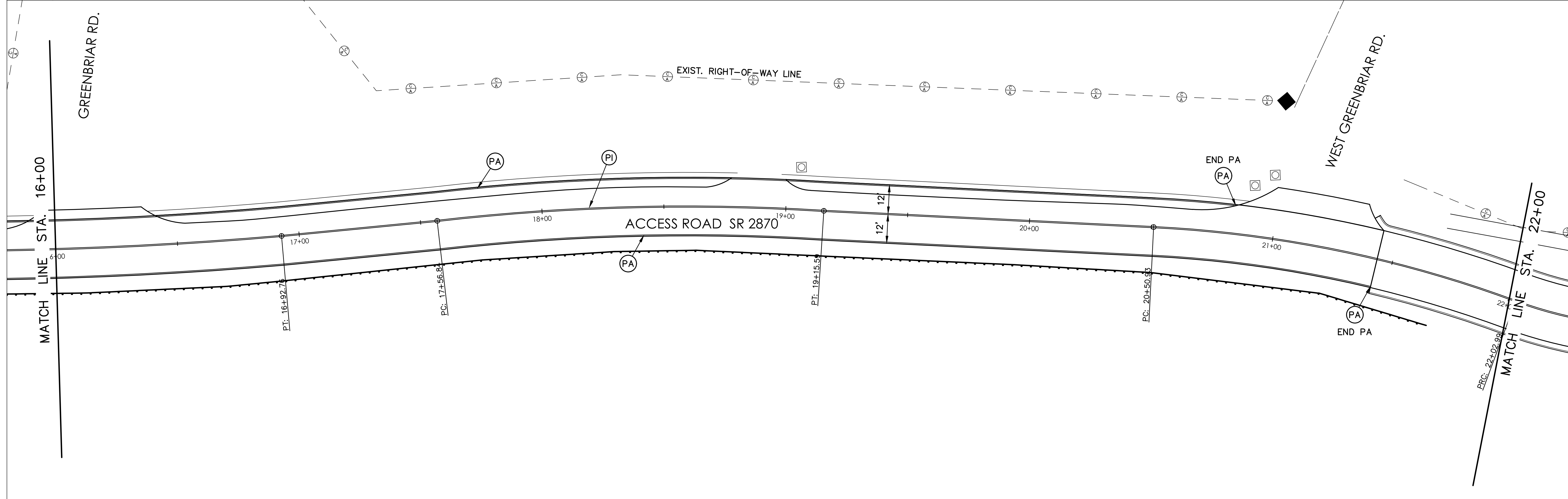
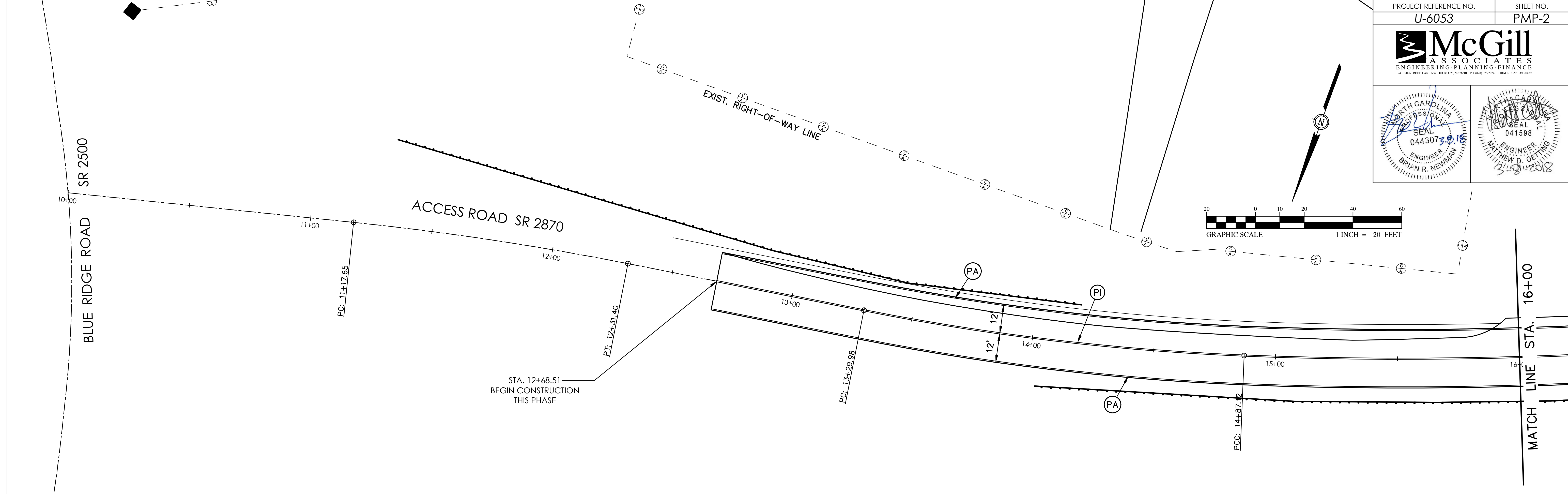
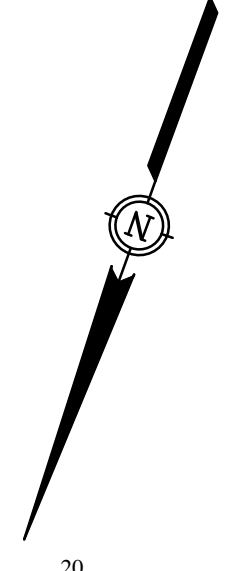
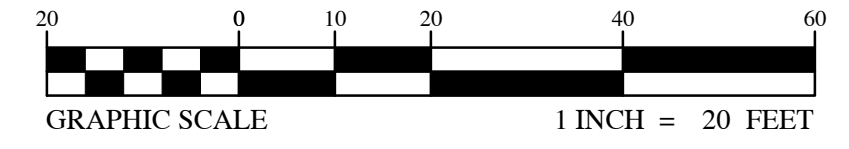



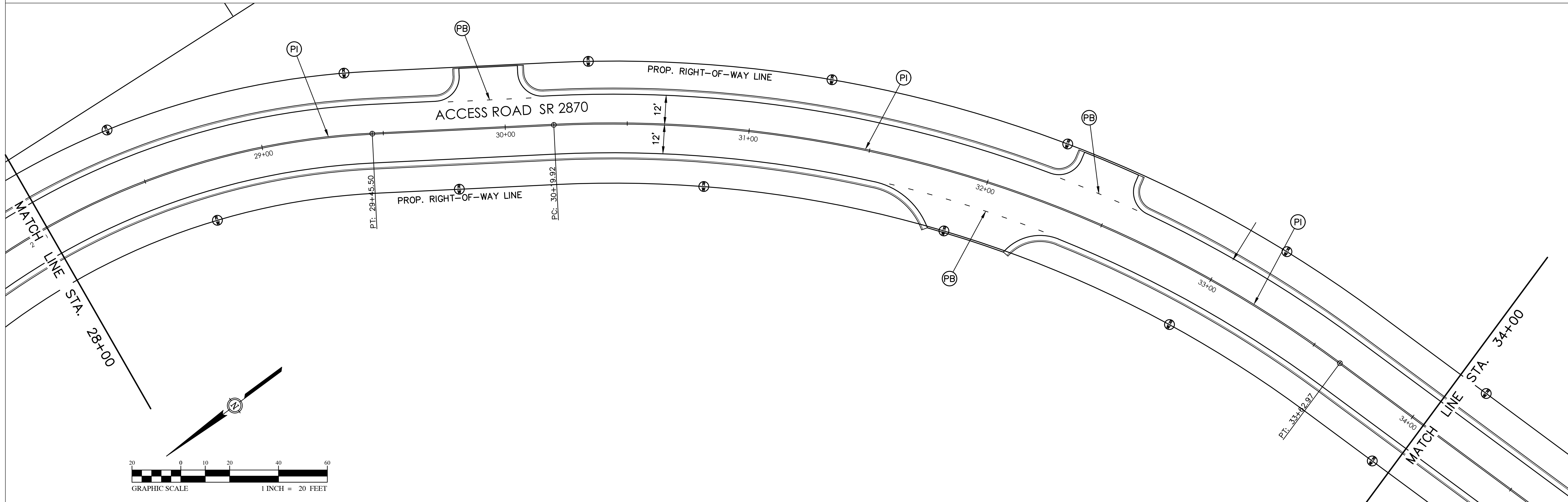
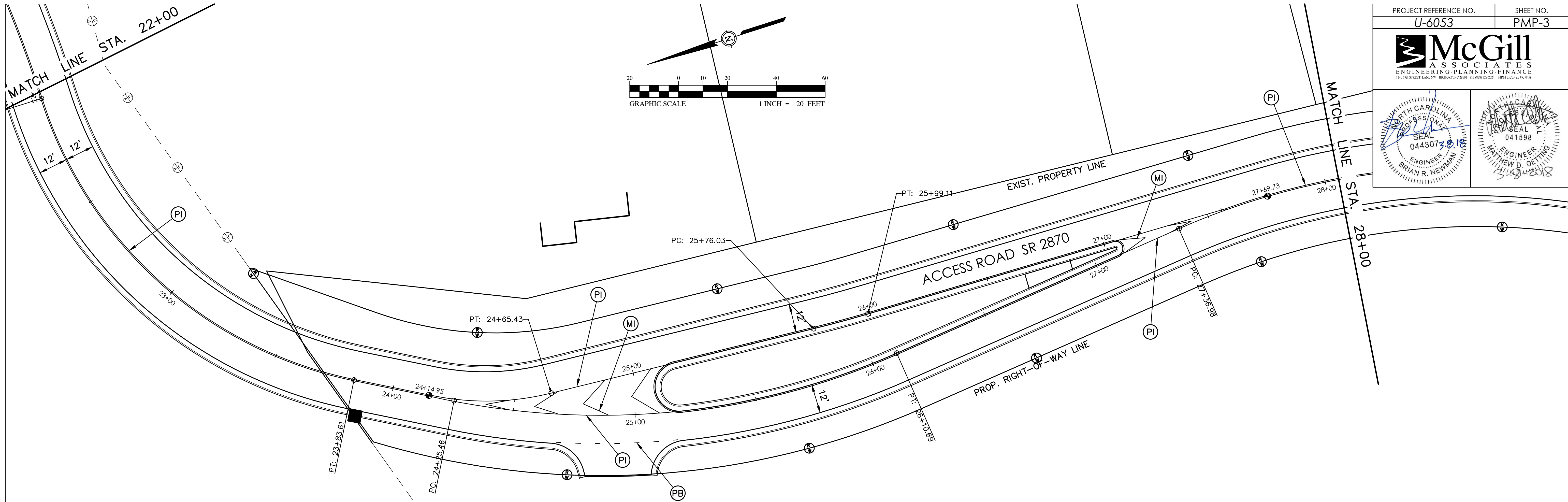

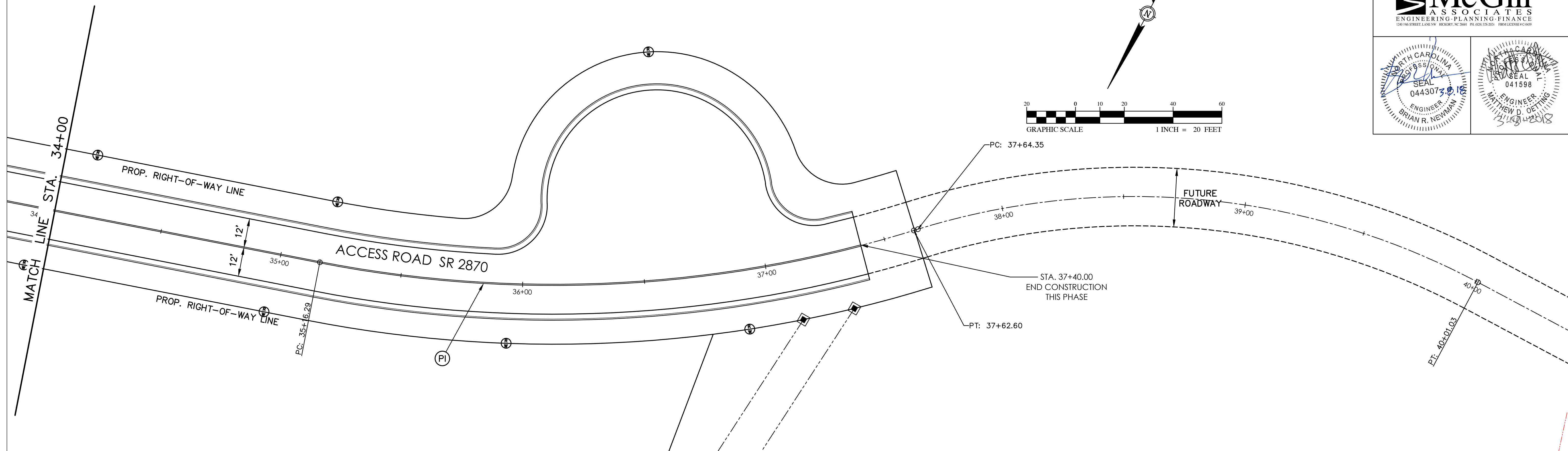
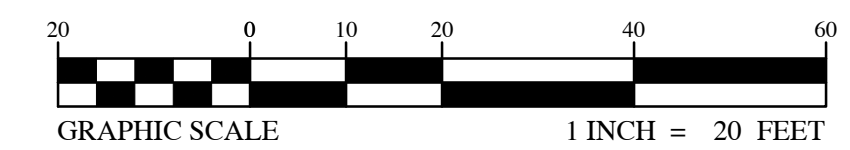
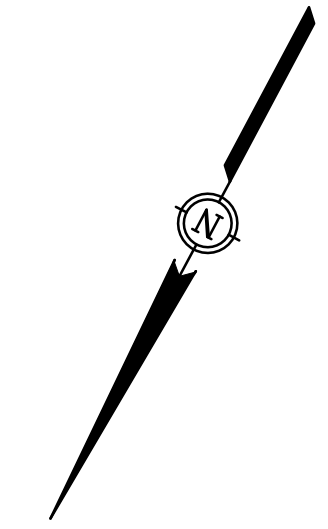

CONTRACT: DM00238 TIP PROJECT: U-6053

CONTRACT: DM00238

STATE	STATE PROJECT REFERENCE NO.	SHEET NO.	TOTAL SHEETS
N.C.	U-6053	EC-1	
STATE PROJ. NO.	F.A. PROJ. NO.	DESCRIPTION	
46961.1.1	APD - 0040 (056)	P.E.	
46961.3.1	APD - 0040 (056)	CONST.	

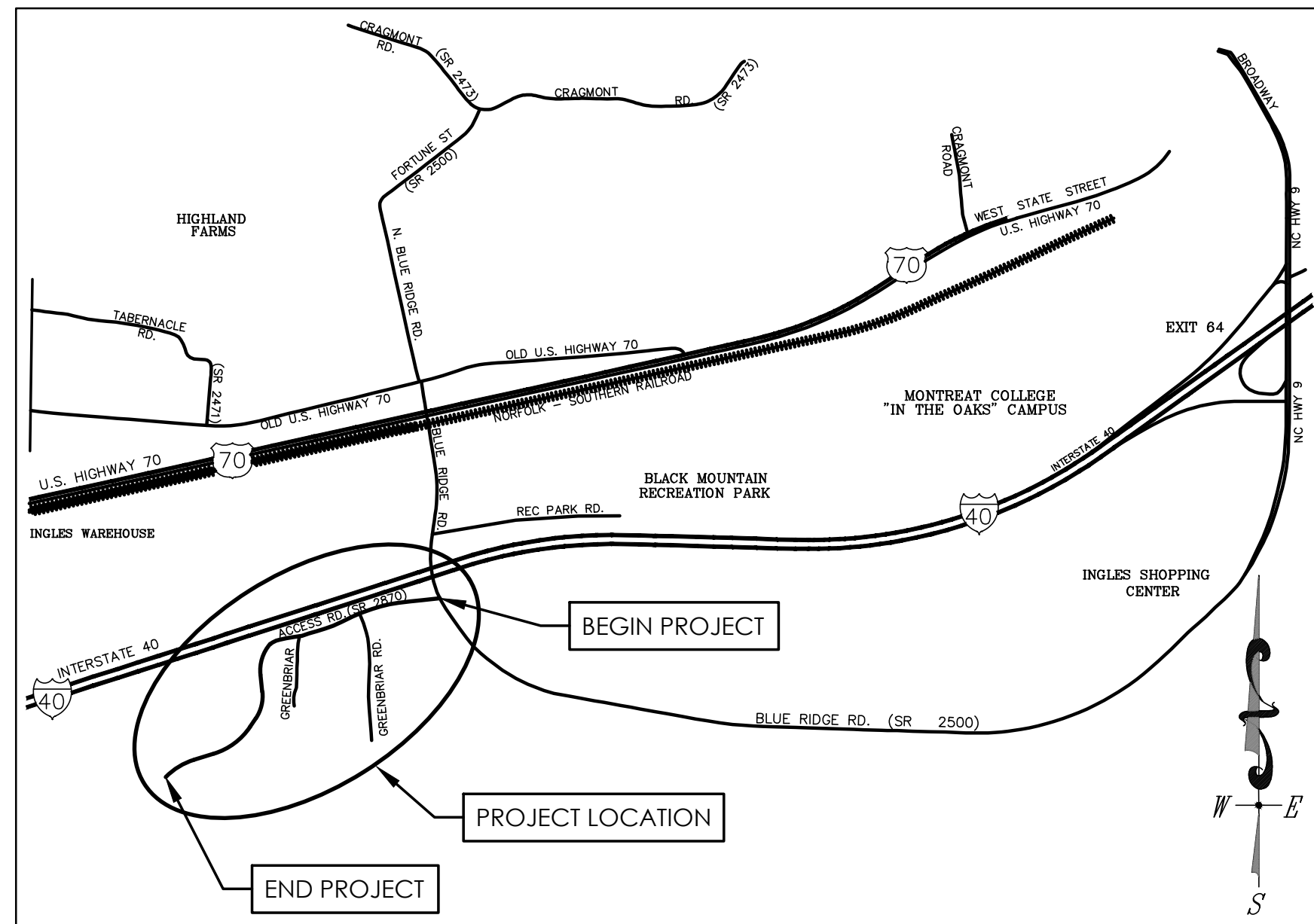

**VICINITY MAP**

# STATE OF NORTH CAROLINA DIVISION OF HIGHWAYS

## PLAN FOR PROPOSED ACCESS ROAD EROSION CONTROL **BUNCOMBE COUNTY**

**LOCATION : ACCESS ROAD SR 2870 IN  
BLACK MOUNTAIN, NC**

**TYPE OF WORK : GRADING, PAVING, DRAINAGE,  
AND PAVEMENT MARKINGS**

**EROSION AND SEDIMENT CONTROL MEASURES**

Std #	Description	Symbol
1605.01	Temporary Silt Fence	
1607.01	Gravel Construction Entrance	
1622.01	Temporary Slope Drain with Earthen Berm	
1630.02	Temporary Silt Basin, Type-B	
1630.05	Temporary Diversion	
1631.01	Matting Installation	
1632.03	Rock Inlet Sediment Trap Type C	
1633.01	Temporary Rock Silt Check Type A	
1633.02	Temporary Rock Silt Check Type B	
	Wattle/Coir Fiber Wattle	
1645.01	Temporary Stream Crossing	
	Clean Water Swale	

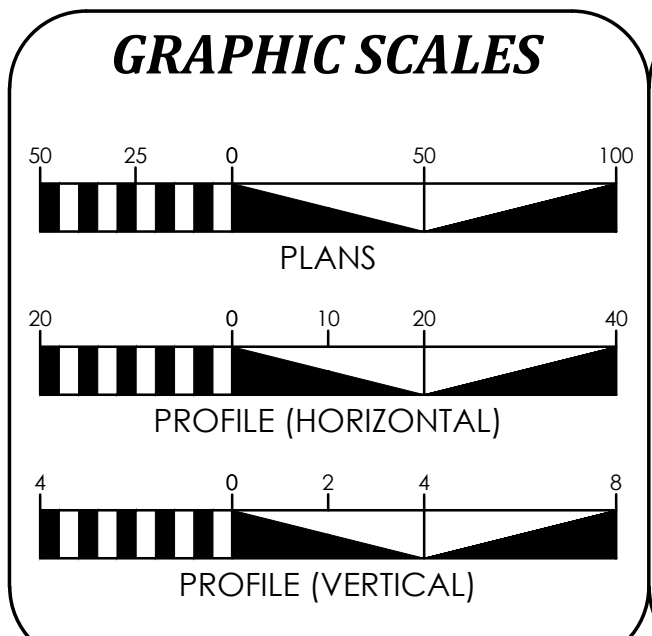
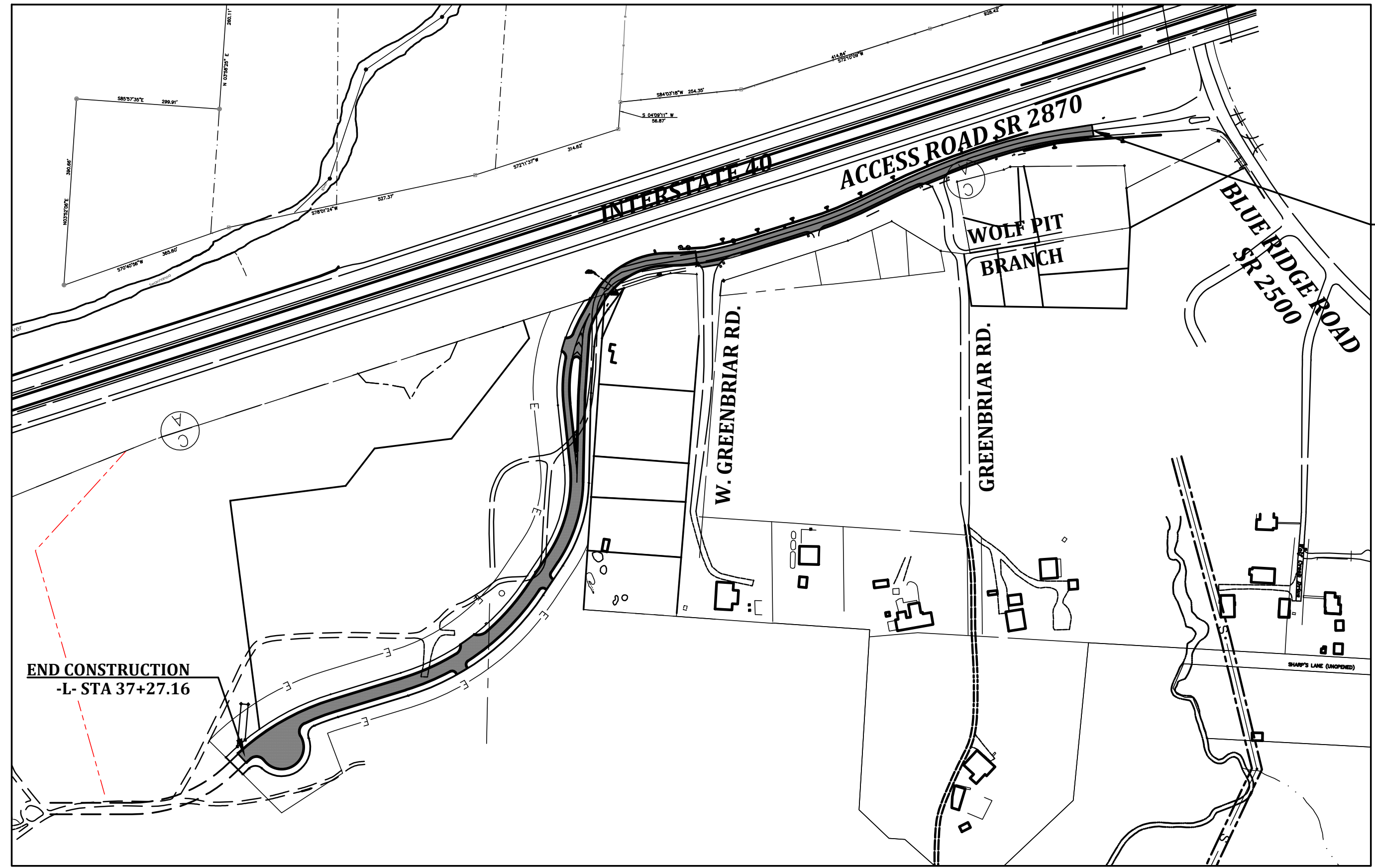

**ROADSIDE ENVIRONMENTAL UNIT  
DIVISION OF HIGHWAYS  
STATE OF NORTH CAROLINA**

THESE EROSION AND SEDIMENT CONTROL PLANS COMPLY WITH THE REGULATIONS SET FORTH BY THE GENERAL CONSTRUCTION PERMIT NCS000250 EFFECTIVE OCTOBER 1, 2015 ISSUED BY THE NORTH CAROLINA DEPARTMENT OF ENVIRONMENT AND NATURAL RESOURCES DIVISION OF ENERGY, MINERAL AND LAND RESOURCES.

**Roadway Standard Drawings**

The following roadway english standards as appear in "Roadway Standard Drawings" - Roadway Design Unit - N.C. Department of Transportation - Raleigh, N.C., dated January 2018 and the latest revision thereto are applicable to this project and by reference hereby are considered a part of these plans.

1605.01 Temporary Silt Fence	1632.03 Rock Inlet Sediment Trap Type C
1607.01 Gravel Construction Entrance	1633.01 Temporary Rock Silt Check Type A
1630.02 Temporary Silt Basin Type B	1633.02 Temporary Rock Silt Check Type B
1630.05 Temporary Diversion	Wattle / Coir Fiber Wattle
1631.01 Matting Installation	1645.01 Temporary Stream Crossing Clean Water Swale

**PLANS PREPARED BY:**

**McGill ASSOCIATES**  
ENGINEERING-PLANNING-FINANCE  
1200 7th STREET, LANE SW, HICKORY, NC 28601 TEL: (815) 224-2024 FAX: (815) 224-0459

2018 STANDARD SPECIFICATIONS	BRIAN R. NEWMAN, PE PROJECT ENGINEER
RIGHT OF WAY DATE: -	JOHN VILAS 3442 DESIGN ENGINEER LEVEL III CERT. NO.
LETTING DATE: MAY 02, 2018	

NCDOT CONTACT: TROY S. WILSON, PLS DIV 13 DISTRICT ENGINEER

**HYDRAULICS ENGINEER**

SIGNATURE: \_\_\_\_\_

**ROADWAY DESIGN ENGINEER**

SIGNATURE: \_\_\_\_\_

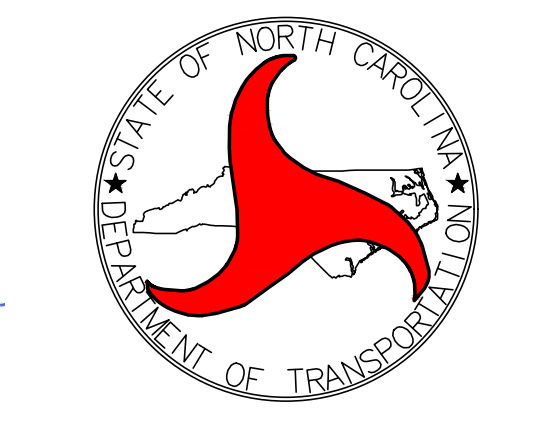

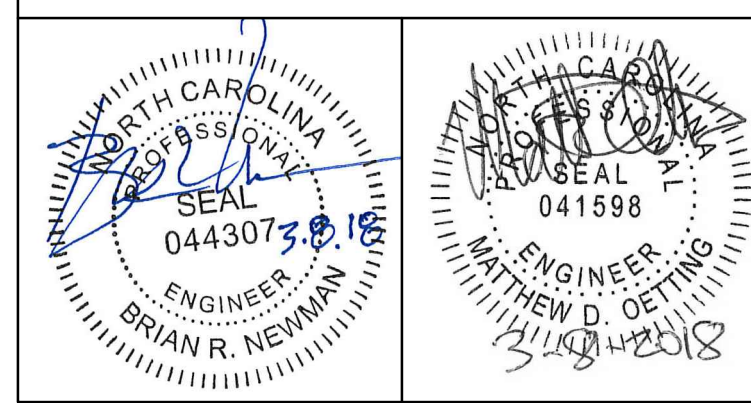

STATE OF NORTH CAROLINA  
DIVISION OF HIGHWAYS

# INDEX OF SHEETS, GENERAL NOTES, AND STANDARD DRAWINGS

## INDEX OF SHEETS

SHEET NUMBER:	SHEET TITLE
EC-1	TITLE SHEET
EC-1A	INDEX OF SHEETS, GENERAL NOTES, AND STANDARD DRAWINGS
EC-1B	EROSION CONTROL PLAN
EC-1C	EROSION CONTROL PLAN

## STANDARD DRAWINGS

2018 ROADWAY ENGLISH STANDARD DRAWINGS

The following Roadway Standards appear in "Roadway Standard Drawings" Highway Design Branch - N.C. Department of Transportation - Raleigh, N.C., Dated January, 2018 are applicable to this project and by reference hereby are considered a part of these plans:

STD. NO.	TITLE
<u>DIVISION 16 - EROSION CONTROL AND ROADSIDE DEVELOPMENT</u>	

- 1605.01 Temporary Silt Fence
- 1607.01 Gravel Construction Entrance
- 1622.01 Temporary Slope Drain with Earthen Berm
- 1630.02 Temporary Silt Basin Type B
- 1630.05 Temporary Diversion
- 1631.01 Matting Installation
- 1632.03 Rock Inlet Sediment Trap Type C
- 1633.01 Temporary Rock Silt Check Type A
- 1633.02 Temporary Rock Silt Check Type B  
Wattle / Coir Fiber Wattle
- 1645.01 Temporary Stream Crossing  
Clean Water Swale

## EROSION CONTROL NOTES

### GRADING AND SURFACING OR RESURFACING AND WIDENING:

THE GRADE LINES SHOWN DENOTE THE FINISHED ELEVATION OF THE PROPOSED SURFACING AT GRADE POINTS SHOWN ON THE TYPICAL SECTIONS. WHERE NO GRADE LINES ARE SHOWN, THE PROFILES SHOWN DENOTE THE TOP ELEVATION OF THE EXISTING PAVEMENT ALONG THE CENTER LINE OF SURVEY ON WHICH THE PROPOSED RESURFACING WILL BE PLACED. GRADE LINES MAY BE ADJUSTED BY THE ENGINEER IN ORDER TO SECURE A PROPER TIE-IN.

### CLEARING:

CLEARING ON THIS PROJECT SHALL BE PERFORMED TO THE LIMITS ESTABLISHED BY METHOD II.

### EROSION CONTROL SCHEDULE:

1. Generally, the order of installation of the erosion control measures will be as follows:
  - 1.1. Construction entrance shall be installed; the temporary silt basins shall be constructed at the low point of the site; and associated diversions and clean water swales installed as indicated on the plan before clearing and grubbing begins.
  - 1.2. Silt fences and temporary silt ditches shall be installed after clearing and before grading.
  - 1.3. Temporary rock silt checks or wattles shall be installed in all disturbed areas as soon as the disturbance begins.
  - 1.4. Final stone ditch checks or wattles shall be installed upon ditch line completion.
  - 1.5. Pipe outlet and inlet protection shall be completed immediately after pipe installation.
2. Other permanent erosion control measures are to be implemented as soon as practical.
3. Temporary rock silt checks, type A will be spaced by percent grade as shown in the erosion control plan.
4. No. 5 stone, or equivalent, will be used in conjunction with the temporary rock silt checks in locations where water is leaving the project or entering a pipe.
5. All devices are to be cleaned out when half full.
6. Establish permanent vegetation per ground stabilization chart.

### GROUND STABILIZATION SCHEDULE

SITE AREA DESCRIPTION	STABILIZATION TIMEFRAME	STABILIZATION TIMEFRAME EXCEPTIONS
PERIMETER DIKES, SWALES DITCHES AND SLOPES	7 DAYS	NONE
HIGH QUALITY WATER (HGW) ZONES	7 DAYS	NONE
SLOPES STEEPER THAN 3:1	7 DAYS	IF SLOPES ARE 10' OR LESS IN LENGTH AND ARE NOT STEEPER THAN 2:1, 14 DAYS ARE ALLOWED
SLOPES 3:1 OR FLATTER	14 DAYS	7-DAYS FOR SLOPES GREATER THAN 50 FEET IN LENGTH
ALL OTHER AREAS WITH SLOPES FLATTER THAN 4:1	14 DAYS	NONE (EXCEPT FOR PERIMETERS AND HGW ZONES)

## MAINTENANCE PLAN

1. ALL EROSION AND SEDIMENT CONTROL PRACTICES SHALL BE CHECKED FOR STABILITY AND OPERATION FOLLOWING EVERY RUNOFF PRODUCING RAINFALL BUT IN NO CASE NOT, LESS THAN ONCE EVERY WEEK. ANY NEEDED REPAIRS SHALL BE MADE IMMEDIATELY TO MAINTAIN ALL PRACTICES AS DESIGNED.
2. SEDIMENT SHALL BE REMOVED FROM BEHIND THE SILT FENCE WHEN IT BECOMES APPROX. 0.5 FEET DEEP AT THE SILT FENCE. THE SILT FENCE SHALL BE REPAIRED AS NECESSARY TO MAINTAIN A BARRIER.
3. ALL SEEDED AREA SHALL BE FERTILIZED, RE-SEEDED AS NECESSARY, AND MULCHED ACCORDING TO SPECIFICATIONS IN THE SEEDING SPECIFICATION TO MAINTAIN A VIGOROUS AND DENSE VEGETATIVE COVER.
4. MAINTAIN ALL MATTING THAT HAS BEEN PLACE ON SLOPES AND IN DITCHES. CHECK FOR GOOD GROUND CONTACT AND FOR THE OCCURRENCE OF ANY EROSION UNDER THE MATTING. MONITOR AND REPAIR OR REPLACE AS NECESSARY.

# STATE OF NORTH CAROLINA DIVISION OF HIGHWAYS

## EROSION CONTROL SHEET

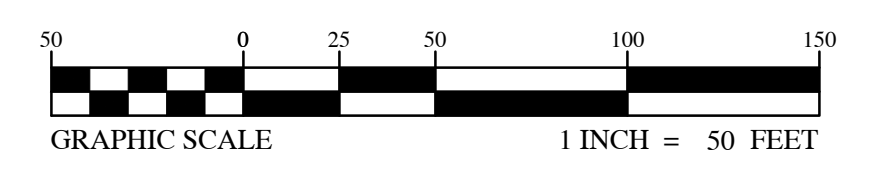
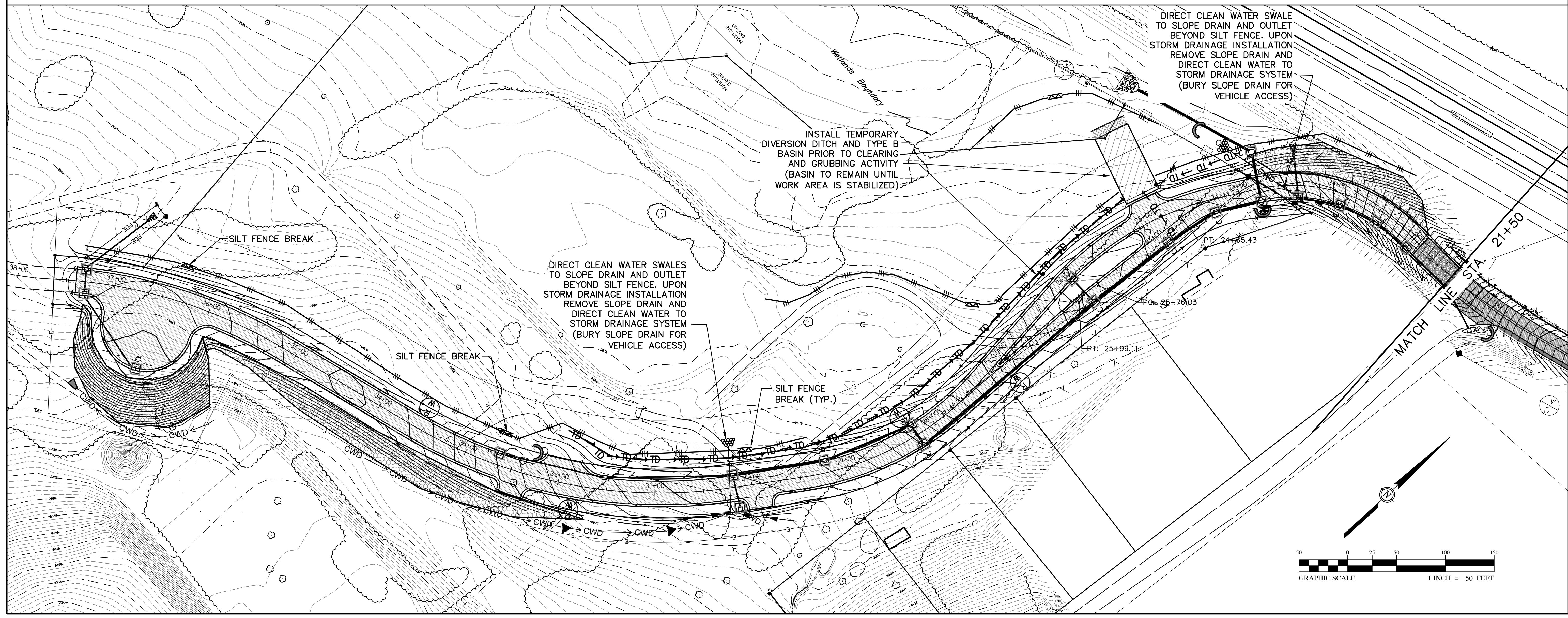
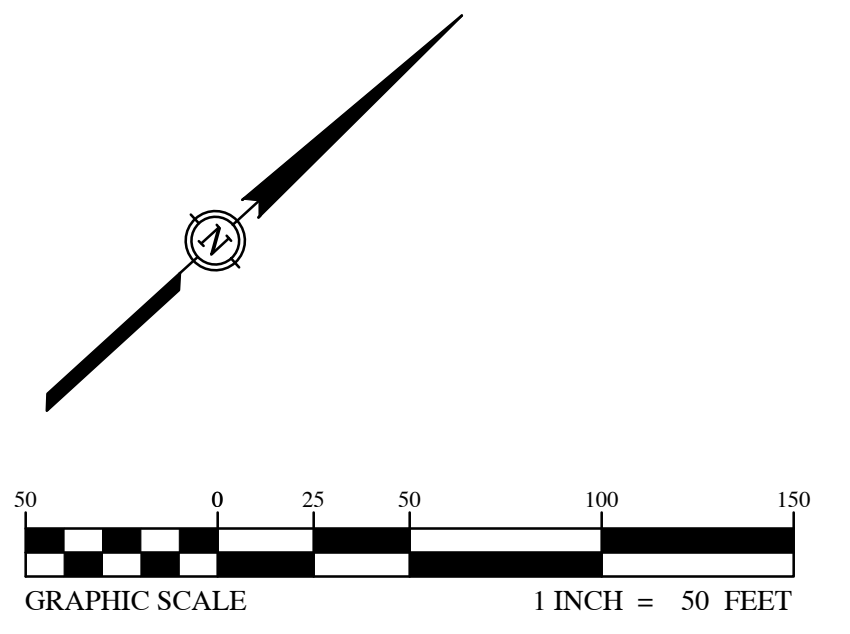
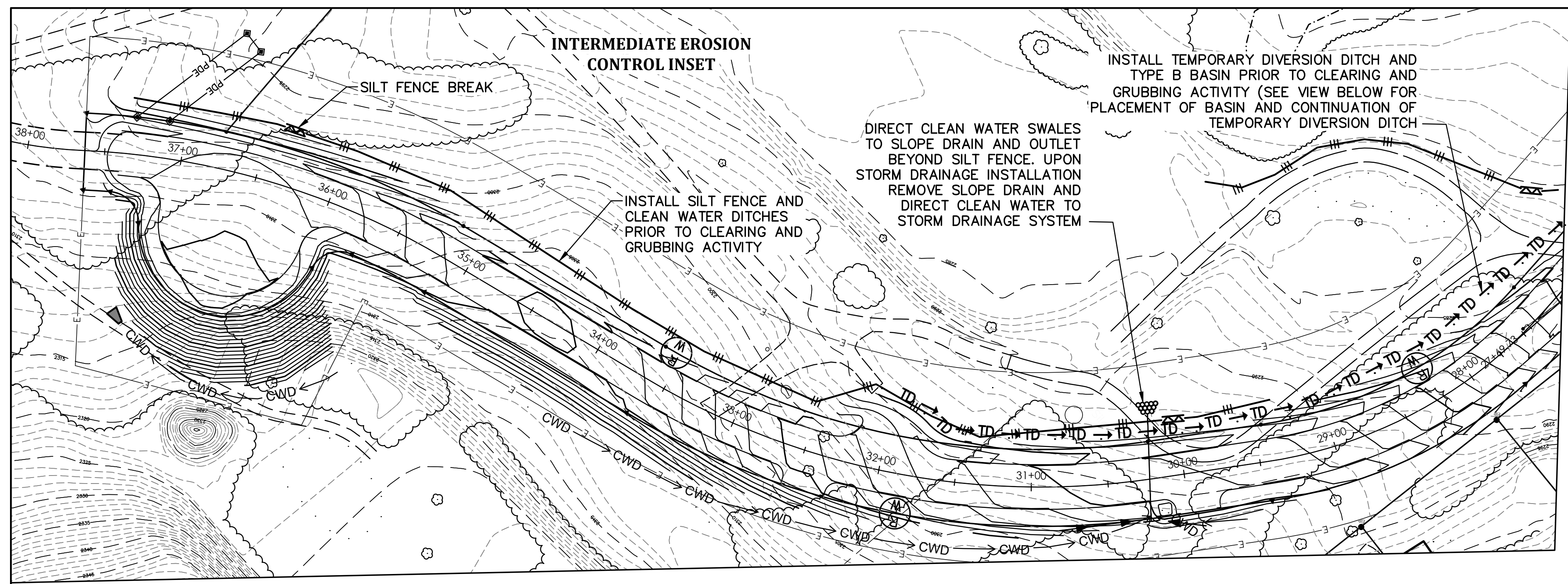

# STATE OF NORTH CAROLINA DIVISION OF HIGHWAYS *EROSION CONTROL SHEET*

